

Operating & Assembly Manual W8ZR StationPro I

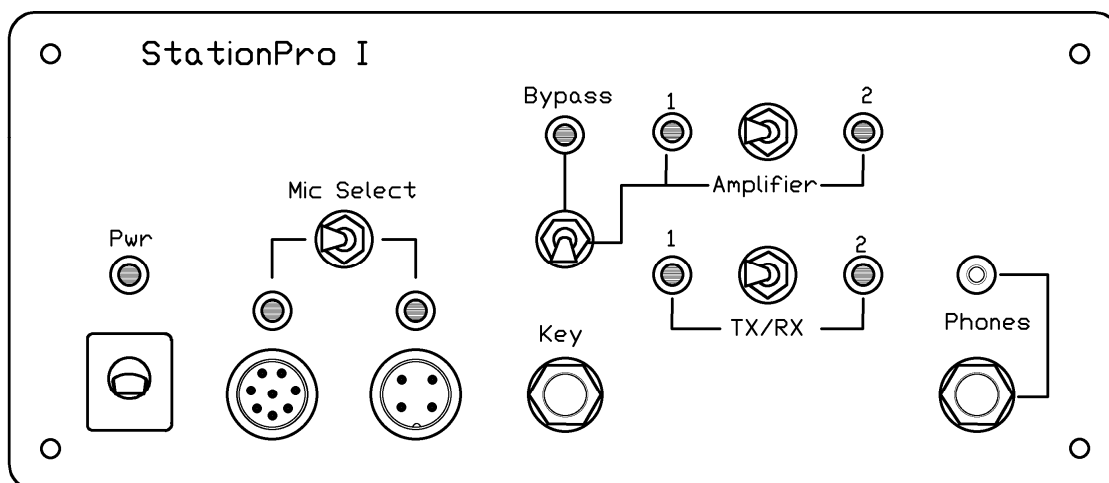

Contact Information: Jim Garland W8ZR
102 Spur Ranch Road
Santa Fe, NM 87540
w8zr@arrl.net
<http://www.w8zr.net>

Copyright © 2010, W8ZR
All rights reserved

(rev. 4/22/2010)

Contents

A. Operating Instructions

I. Introduction	3
II. Specifications	3
III. Front Panel Controls and Connectors	5
IV. Rear Panel Connections	7
V. RF Relay Unit Connections	11
VI. Installation and Hookup	12
VII. Operating Instructions and Hints	14
VIII. A Final Comment from W8ZR	14

B. Assembly Instructions

I. Preparation for Assembly.....	15
II. Microphone Jack Considerations.....	16
III. Front Panel Assembly	17
IV. Main Circuit Board Assembly.....	25
V. Rear Panel Circuit Board Assembly.....	32
VI. Final Assembly of the Controller	34
VII. RF Relay Unit Assembly	38
VIII. Transceiver Pod Assembly	42
IX. Final Instructions	47

Appendix A: Avoiding Ground Loop Complications.....49

Appendix B: Parts & Supplier List 54

(download schematic diagrams from
www.w8zr.net/stationpro/download)

A. StationPro I Operating Instructions

I. Introduction:

The W8ZR StationPro I is a master station controller that integrates seamlessly the switching and control functions of complex amateur stations consisting of two transceivers (or receiver/transmitter pairs) and two linear amplifiers. With the flip of a switch the StationPro I transfers to a selected transceiver the operator's key or paddle, microphone, computer interface, RTTY/packet, line in/out, speaker, and numerous other control functions. A second switch transfers the transceiver's RF output to a selected linear amplifier, along with the amplifier relay and ALC control voltages.

The StationPro I was designed to be as flexible as possible, so as to accommodate almost any amateur equipment, from vintage "boatanchor" rigs of the vacuum tube era to computer-interfaced contemporary transceivers. Operators need not fear incompatibility between their linear amplifiers and transceivers, since the StationPro I includes a relay driver circuit that can accommodate any amplifier's relay requirements. The RF relay circuits in the StationPro I introduce negligible VSWR from 1.8-54 MHz and are conservatively rated at the U.S. legal power limit. As a builder's station needs evolve, the StationPro I can easily be upgraded to the microprocessor-controlled StationPro II by changing front panels and adding a microcontroller printed circuit board.

II. Specifications:

RF Relay Circuits

1. Frequency Range: DC – 54 MHz
2. Nominal Impedance: 50 Ω unbalanced (SO-239 connectors)
3. Insertion VSWR: less than 1.1 (DC-30 MHz), less than 1.2 (54 MHz)
4. RF Power Rating: U.S. amateur legal power limit (1500 Watts)
 Note: tested at 2500 Watts below 30 MHz, 800 Watts at 54 MHz.
 Relay contacts rated at 12A DC continuous, 5000V dielectric rating (to coil)
5. Relay Control Voltage: +12V DC, supplied by control unit.
6. Relay Control Cable: Ethernet CAT5 cable, with RJ-45 connectors

Data, DC & Audio Control Circuits

7. Transceivers or Receiver/Transmitter Pairs: 2
8. Linear Amplifiers: 2

9. Amplifier Relay Control:

- switching time: 3 mS maximum (on), 1 mS maximum (off)
- control voltage (open circuit) 12VDC
- control current (closed circuit) 5 mA
- relay keying limits (Option A or B selected during assembly)
 - Option A: 400V (AC or DC of either polarity) @ 250 mA maximum
 - Option B: 200V positive DC only @ 3.5Amperes maximum

10. Microphones: 1 or 2 (up to 7 wires plus GND per microphone)

11. Microphone Connectors: owner's choice, two 8 pin-standard supplied.

12. Headphone Connectors: 1/4 in. & 3.5 mm. stereo, automatic speaker disconnect

13. Transceiver Control Lines: 24 maximum per transceiver (plus GND)

- Microphone (Mic+, Mic-, PTT, + four functions): 7
- Speakers/Phones (L/R): 2
- Key/Paddle: 2
- Line In (mono): 1
- Line Out (L/R stereo): 2
- Amp Relay: 1
- Amp ALC: 1
- Computer Serial (TXD, RXD, CTS, RTS): 4
- Aux/Spare: 4

14. Transceiver Interface Cable: 25C shielded, w/25 pin D-SUB connectors

15. Transceiver Control Relay Ratings:

- max. switched current: 3A, derate as switched voltage increases
- max. switched voltage: 125 VDC (25 mA), 150 VAC (100mA)

16. Optional RF Relay Power: 30VDC maximum (2.5mm DC power jack)

17. Switched DC Output: +12VDC in series with 1000 Ω resistor

General Specifications

18. Power Requirements:

12VDC @ 400 mA nominal (2.5 mm DC power jack)

Fuse (internal): 1A-3AG

19. Dimensions:

Control Unit

Height: 4.2" (10.7 cm), excluding feet

Width: 9.5" (24.1 cm)

Depth: 8.0" (20.3 cm), including front/rear connectors & switches

RF Relay Unit

Height: 5.0" (12.7 cm)

Width: 7.5" (19.1 cm), (excluding mounting flanges)

Depth: 1.5" (3.8 cm)

20. Weight:

Control Unit: 4 lbs-4 oz. (1.93 kg)

RF Relay Unit: 1 lb-10 oz. (0.74 kg)

III. Front Panel Controls and Connectors

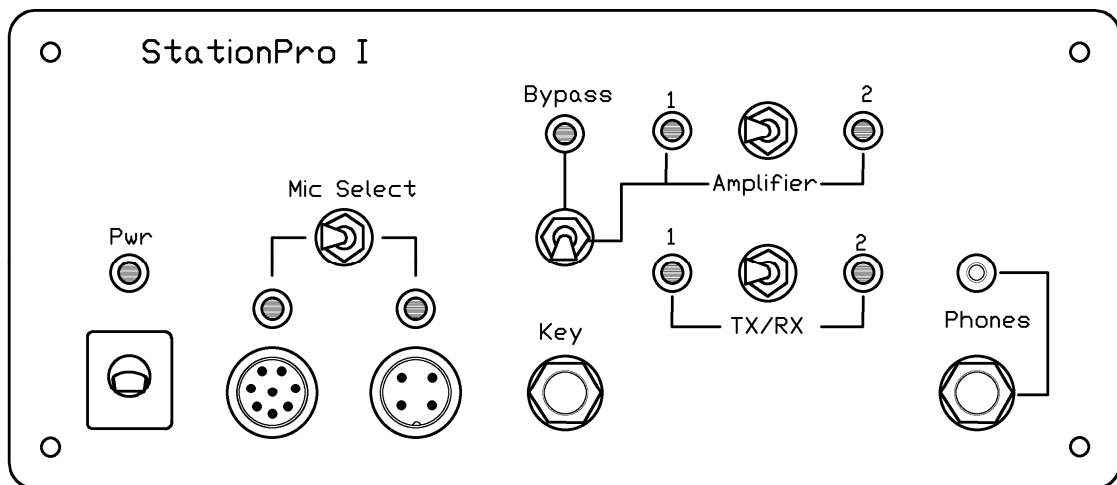

1. Pwr Switch: Connects +12VDC from rear panel power jack to StationPro circuitry, through a 1A fuse. Also applies +12VDC (through a series 1000 Ω resistor) to a rear panel jack for controlling an optional master station AC power relay.

2. Mic Sel. Switch: Switches between two front panel microphones. Each microphone can have up to 7 audio/control wires. The Mic+ and PTT are independently switched but the other wires (Mic-, FCN1, etc.) are common to both microphones. As shown in the drawing, the microphones can have different connector types. Instructions for wiring the microphone jacks are given in the next section, **B: StationPro I Assembly Instructions**.

3. Key Jack: A key or paddle can be connected to this standard 1/4" stereo jack, with normally open contacts. Keyer paddles should be wired so that the plug tip = dot, and the plug ring = dash. For convenience, an identical key jack on the rear panel is wired in parallel with this jack.

4. TX/RX Sel. Switch: This toggle switch switches a station transceiver or receiver/transmitter pair and lights the appropriate LED.

5. Amplifier Sel. Switch: This toggle switch select a linear amplifier and lights the appropriate LED.

6. Amp Bypass Switch: When activated, this switch operates a bypass relay in the remote RF relay unit that deselects both linear amplifiers and connects the selected transceiver directly to the output (antenna) jack. It also locks out the amplifier keying circuit to prevent inadvertent keying up of an amplifier.

7. Phones jacks (2): Twin stereo headphone jacks can accommodate either 1/4 in. or 3.5 mm (1/8 in.) stereo headphones (Left = tip, Right = ring). These jacks are connected to the left/mainRX and right/subRX speaker outputs of the selected transceiver; plugging in a set of headphones automatically disables the speakers.

IV. Rear Panel Connections

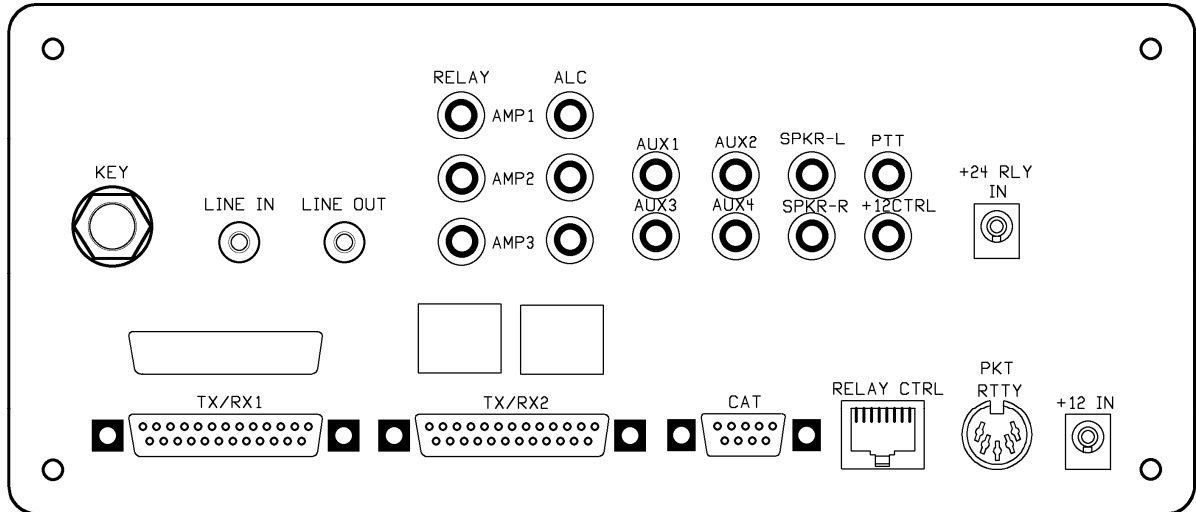

1. TX/RX1, TX/RX2 jacks: D-SUB 25 pin male jacks that connect via breakout “pods” to the station transceivers. The pinout of these jacks is as follows:

Pin No.	Function	Pin No.	Function
1	Mic +	19	Aux/Spare 3
2	PTT	20	Line IN
3	Mic -	21	CAT - CTS
4	Mic FN1	22	CAT - TXD
5	Mic FN2	23	CAT - RTS
6	Mic FN3	24	CAT - RXD
7	Mic FN4	25	GND
8	Key - Ring		
9	Key - Tip		
10	Line Out - L		
11	Line Out -R		
12	Spkr - L		
13	Spkr - R		
14	Amp Relay		
15	Amp ALC		
16	Aux/Spare 2		
17	Aux/Spare 1		
18	Aux/Spare 4		

2. KEY Jack: A key or paddle can be connected to this standard 1/4" stereo jack, with normally open contacts. Keyer paddles should be wired so that the plug's tip = dot, and the plug's ring = dash. An identical key jack on the front panel is wired in parallel with this jack.

3. LINE IN Jack: This 3.5 mm (1/8") mono jack is typically connected to the output from a computer sound card or a TNC. The connected device is routed by the StationPro to the Line In port of the selected transceiver.

4. LINE OUT Jack: This 3.5 mm. (1/8") stereo jack outputs the Line Out port of a selected transceiver. Normally, the tip would be the left or main receiver line output and the ring would be the right or sub-receiver output. The jack is typically used to interface a transceiver's line output to the input of a computer sound card or TNC.

5. AMP RELAY (3) and AMP ALC (3) jacks: These RCA phono jacks should be jumpered (use shielded phono cables) to the relay and ALC jacks of the station's linear amplifiers. Because the Amp Relay outputs are buffered by a solid state switching circuit, the user need not fear compatibility problems between a selected amplifier and transceiver.

6. AUX1 through AUX4 Jacks: These RCA phono jacks are spares that can be used for any control purpose by the user. The StationPro routes these jacks to spare pads on the breakout pod associated with a selected transceiver. They can be used for, e.g., band data switching.

7. SPKR-L and SPKR-R Jacks: The station's speakers should be connected to these RCA phono jacks and are routed by the StationPro to the speaker output ports of a selected transceiver. Normally SPKR-L would be used for the main receiver's speaker and SPKR-R for the sub-receiver's speaker. These jacks are disconnected when headphones are inserted into a front panel jack on the StationPro.

8. PTT Jack: This RCA phono jack is wired in parallel with the PTT line on the microphone and also with pin 3 of the Packet/RTTY jack. Grounding this line actuates the PTT circuit of the selected transceiver. A typical use would be to connect a foot switch to this jack. Note that some transceivers ground their PTT line when transmitting, so that this jack could be used in this instance for, e.g., external receiver muting.

9. +12 CTRL Jack: This RCA phono jack outputs +12VDC when the StationPro's power switch is turned on. The +12V is in series with a 1000 Ω resistor, which limits the short circuit current to 12 mA. Because of the series resistor, the jack *cannot* be used to power 12V accessories. This switched jack is intended to control a (user-supplied) solid state AC power relay, which can be used as a master station power ON/OFF relay. Below is a sample circuit diagram using an SPST solid state AC relay. Any solid state relay that operates with a DC control control voltage of 3-15V (or more) can be used. The relay

should have a load current rating of at least 25A. A DPST solid state relay can be used if the builder wishes to switch both sides of the 120VAC line.

A convenient way to make this master station power controller is to mount the solid state relay in the bottom of a deep duplex outlet box, available at Home Depot or any electrical supply store. An ordinary duplex outlet (two 120VAC receptacles) is mounted on the face of the box, and a heavy duty AC power cord exits through one of the side holes. A fuse holder and an RCA phono jack mount on the other side of the outlet box. A shielded phono cable connects this phono jack to the 12V SWITCHED jack on the rear panel of the StationPro, and an outlet strip for the station equipment plugs into one of the two duplex receptacles. The other duplex receptacle can be wired directly to the 120V line, to provide an unswitched 120VAC outlet for station clocks, computer, UPS supply, etc.

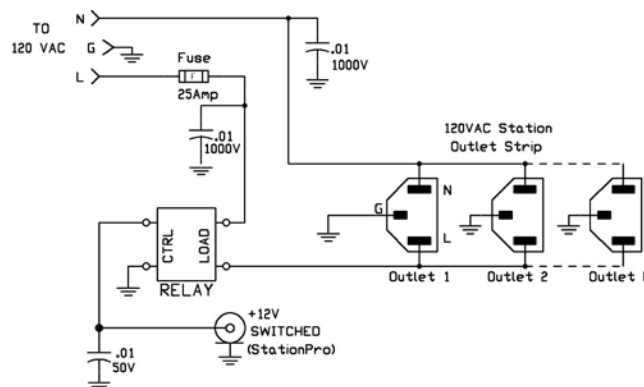

MASTER STATION 120 VAC POWER CONTROLLER
(Note that the .01 $\mu\text{F}/1000\text{V}$ bypass capacitors should be 240 VAC line-rated)

10. +24V RLY IN Jack: This 2.5 mm DC power jack may be used to connect an external DC power supply (+15V to +30V) to user-supplied external RF relays. This jack is not used with the standard RF relay unit. Some users, however, may prefer to build their own RF relay units using, e.g., surplus vacuum relays, which typically operate at 24-28V. In this case, the StationPro will automatically connect the relays to this external power source.

11 REM IN & REM OUT Jacks: Not used in the StationPro I. The cutouts are blanked off with a cover plate.

12. CAT Jack: This female D-SUB 9 pin (DB9) connector is configured as a standard serial port and should be connected to the serial port on a computer or other peripheral equipment. The required cable is an ordinary 9 pin serial cable terminated with male and female DB9 connectors. The StationPro I routes this port to the selected transceiver. The (industry standard) pinout of this connector is as follows:

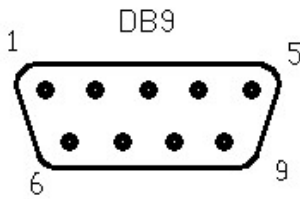

DB9 CAT Connector	
Pin No.	Function
1	N/C
2	RXD
3	TXD
4	N/C
5	GND
6	N/C
7	RTS
8	CTS
9	N/C

13. RELAY CTRL Jack: This RJ45 jack is used to control the StationPro's remote RF relays. The jack accepts a standard 8-wire ethernet-type patch cable (with RJ45 connectors). The cable should be no longer than necessary (5 – 6 ft or shorter), and preferably shielded. The free end of the cable plugs into a mating connector on the RF relay enclosure. Builders of custom RF relay enclosures should refer to the StationPro schematic diagram for the connector pinout,

14. PACKET/RTTY Jack: This standard 5 pin DIN jack is used to connect RTTY, Packet, and PSK31 peripherals to the StationPro. The pinout is shown in the diagram. Note that all of the pins on this jack are in parallel with similarly named pins on other jacks on the StationPro. The AUX4 pin is not designated for any specific purpose, but may be configured by the user for an additional function (e.g., squelch).

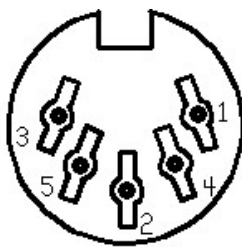

RTTY/PACKET	
1.	PTT
2.	GND
3.	LINE IN
4.	AUX4
5.	LINE OUT-F

15. +12 IN Jack: This DC power jack accepts a standard 2.5 mm DC power plug, which should be connected to a +12V (nominal) regulated DC power supply. This power supply can be a station +12V supply used to power other equipment (e.g., an HF or VHF/UHF FM transceiver), the accessory +12V port on the rear panel of most HF transceivers, or even a dedicated wall-wart supply. (Note however that some wall-warts are poorly filtered and may introduce audio hum into the microphone circuit.) The power supply should be rated at 500 mA or greater.

V. RF Relay Unit Connections



1. TRX1, TRX2 Jacks: These SO-239 (UHF) coaxial cable jacks should be connected to the RF Output (antenna) jacks on the station transceivers, using 50 Ω coaxial cable. Because HF transceivers are rated at 200W RF or less, RG-58 or RG8X cable can be used for these jumper cables. Note that the StationPro grounds the antenna connectors of transceivers that are not selected. The TRX3 jack is not used in the StationPro I.

2. AMP IN (AMP1, AMP2) Jacks: These SO-239 (UHF) coaxial cable connectors should be connected to the RF Input jacks of the station linear amplifiers, using 50 Ω coaxial cable. RG-58 or RG8X cable can be used for these jumper cables. Note that the StationPro grounds the inputs of amplifiers that are not selected. The Amp 3 jack is not used in the StationPro I.

3. AMP OUT (AMP1, AMP2) Jacks: These SO-239 (UHF) coaxial cable connectors should be connected to the RF Output jacks on the station linear amplifiers, using 50 Ω coaxial cable. For legal limit amplifiers, it is best to use RG-8, RG-213, LMR-400 or similar coaxial cable for these jumper cables. Note that the StationPro grounds only the *input* of non-selected amplifiers. The outputs of non-selected amplifiers are left floating as a precaution, since some linear amplifiers, if inadvertently left on-line (this will not happen if the StationPro always controls the amplifiers), may be more prone to instability if their outputs are grounded. Note that a bypass relay in the StationPro RF enclosure routes RF from the selected transceiver directly to the OUTPUT connector when no amplifier is selected. The Amp3 jack is not used in the StationPro I.

4. OUTPUT Jack: This SO-239 (UHF) coaxial cable connector should be jumpered to the station antenna (or antenna switch). The coaxial cable should be rated for the maximum power of any of the station linear amplifiers.

5. CTRL Jack: This RJ45 jack is used to control the RF relays. The jack accepts a standard 8-wire ethernet-type patch cable (with RJ45 connectors). The cable should be

no longer than necessary (5 – 6 ft or shorter), and preferably shielded. The free end of the cable plugs into a mating connector on the rear panel of the StationPro Control Unit.

VI. Installation and Hookup

The StationPro I consists of a main control unit, a remote RF relay unit, and two breakout pods for the station transceivers. The RF relay unit mounts behind the station operating desk and is connected to the main control unit by a standard 8-wire ethernet patch cable, terminated with RJ45 connectors (shielded cable preferred). This cable is readily available from any retail store that sells computer supplies.

The two transceiver breakout pods connect to the main control unit with 25-wire shielded computer cables. For most applications, inexpensive off-the-shelf computer cables can be used, the kind with molded DB25 connectors on each end (one male, one female). However, in some applications involving computer control of both transceivers operating SSB or AM, the builder may have to fabricate custom interface cables having additional shielding. This additional shielding would prevent possible crosstalk between the high level RS-232C data and the microphone audio. This topic is thoroughly discussed in the supplementary manual, “**Preparing Custom Transceiver Interface Cables,**” which can be downloaded from www.w8zr.net/stationpro/download. However, since wiring cables is tedious, the builder should always try a commercial cable first to see if a problem occurs. Furthermore, there are several workarounds discussed in the supplementary manual, short of fabricating custom interface cables.

The diagram on the following page shows how the StationPro I is interfaced to the operator’s station. It is important to note that none of the rear panel jacks on the StationPro I controller connects *directly* to transceivers. All transceiver control functions and inputs (microphone, key, data, speakers, PTT, etc.) are made by cables coming from breakout pods. The fabrication of breakout pods is treated in detail in the next section, **B:StationPro I Assembly Instructions**. The jacks on the rear panel of the StationPro I attach to the station’s peripheral equipment, such as computer, speakers, TNC, and so forth. The StationPro I automatically routes this peripheral equipment to the selected transceiver. Each amplifier’s relay and ALC lines also connect to the StationPro I rear panel. Users should refer to **III. Rear Panel Connectons** for details about connector pinouts.

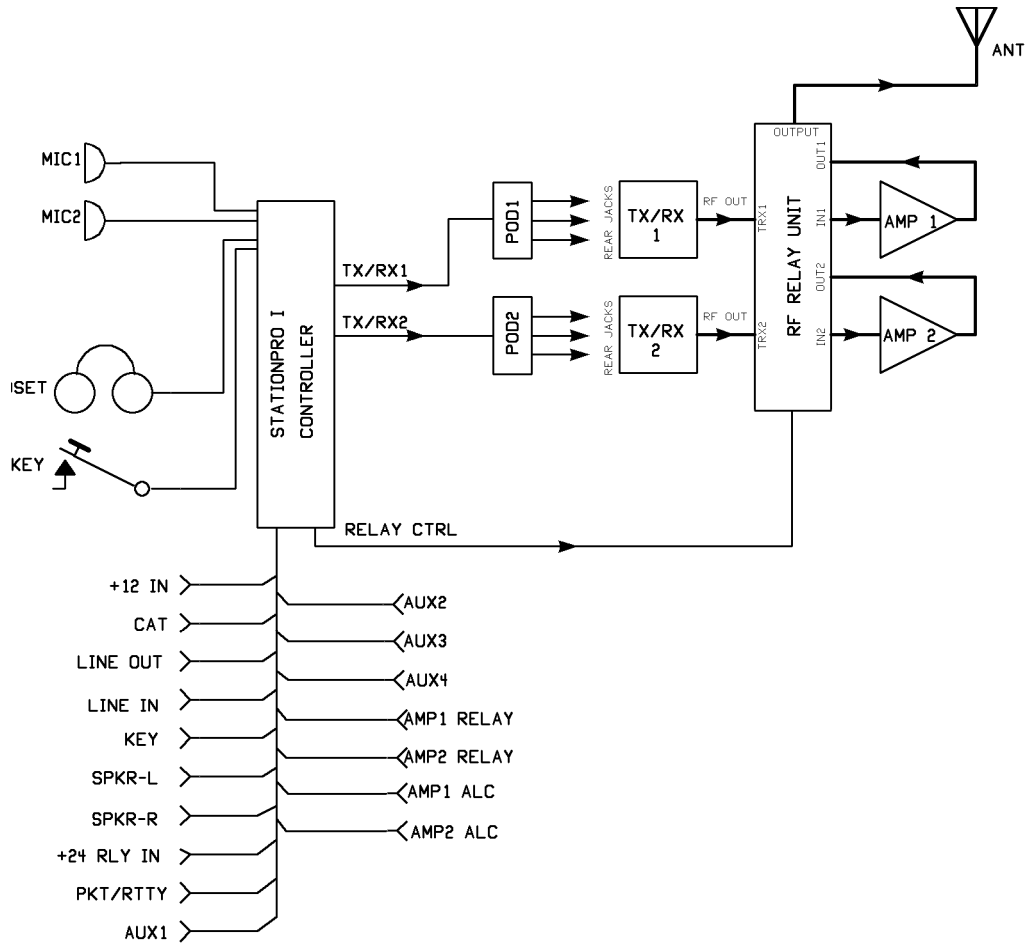

VII. Operating Instructions and Hints

1. Power Up: Once the interconnecting cables are installed and a +12V DC power source (500mA minimum) is plugged into the +12 IN jack on the rear of the StationPro I control unit, the StationPro I can be turned on with the front panel PWR switch. The red LED power indicator will light and the transceiver and amplifier (or amp bypass) indicated by the front panel switches and LEDs will be immediately selected.

2. Transceiver and Amplifier Selection: Station transceivers and amplifiers are selected by toggling the appropriate front panel toggle switches. A green LED indicator will illuminate each selection. If the Amp Bypass switch is on, both amplifiers will be taken off-line and the Amp Bypass LED will light. Note that when the Amp Bypass is selected, an interlock circuit in the StationPro I prevents accidental keying-up of both off-line amplifiers.

VIII. A Final Comment from W8ZR

The philosophy underlying the design of the StationPro I is that an initial investment made in planning and organizing one's station will pay handsome dividends in convenience, time savings, and operating pleasure. The ability instantly and reliably to switch between rigs means that that more time can be spent on the air enjoying the hobby, and fewer frustrating hours spent crouched behind the operating desk, debugging dead connections and miswired cables, and worrying about inadvertently throwing the wrong switch. The StationPro I and its big brother, the StationPro II, have brought for their designer a new enjoyment and satisfaction to amateur radio. It is sincerely hoped that other builders will experience this same enjoyment and satisfaction.

For comments, inquiries, and suggestions either about these instructions or the StationPro I, please email Jim Garland W8ZR at w8zr@arrl.net. A great deal of additional information may also be found on the StationPro website at www.w8zr.net/stationpro/

B. StationPro I Assembly Instructions

The W8ZR StationPro I (SP-I) consists of the primary controller unit, plus an external RF relay unit. In addition, there are two transceiver interface pods that attach to the controller unit with standard 25 pin computer cables. The controller unit contains three printed circuit boards (plus a small jumper board): a front panel circuit board, a rear panel circuit board, and a main circuit board, all of which plug together with short ribbon cables.

The RF relay unit handles all of the RF switching for the user's transceivers and amplifiers. The transceiver interface "pods" are simple breakout boxes that interface to each connected transceiver (or receiver/transmitter pair). Builders should allow about 7-10 hours to wire and test a complete SP-I.

Note: If you received this manual with your W8ZR kit, then please verify that the revision date on the cover corresponds to the revision date of the manual at www.w8zr.net/stationpro/download. The W8ZR website will always have the latest revision number for all documentation and firmware.

(1) Tools: To build the StationPro I you will need the following tools and small items:

- hookup wire #22AWG, 10 ft. approx
- small tip soldering iron
- 1/32" diameter resin core solder
- isopropyl (rubbing) alcohol & Q-tips
- magnifying glass
- small needle-nose pliers
- small flush-cut wire cutters
- Phillips screwdrivers (small and medium)
- small flat head screwdriver
- sharp knife or single-edge razor blade
- 3/16 in. drill bit (5 mm approx.)
- small flat and round files (optional)
- set of nut drivers (optional)
- regular tip soldering iron (optional)
- 1/4 in. heat shrink tubing (optional)
- transceiver cables (see Sec. VIII)





Assembly Hints

1. Make sure your workbench surface is clean and free of clutter.
3. Inventory and sort parts and read through the assembly instructions before you begin construction. Read the FAQs page on the W8ZR StationPro website.
2. Use a high-intensity light and magnifying glass to inspect your solder joints and to look for solder bridges.
4. To give your work a professional appearance, install resistors and capacitors so their color codes and markings all face the same way.
5. Work carefully and methodically and take your time. Take pride in your workmanship, and if you complete a step and it doesn't look good, then do it over.





(2) Hardware: The needed hardware is supplied in two hardware packs with the W8ZR "semi-kits." You will find that there are some extra pieces left over. Save these, because you will need them if you upgrade your StationPro I to a StationPro II in the future.

Note: additional cabinet hardware is packed with the enclosure for the SP-II control unit. Threaded aluminum standoffs are supplied by Mouser Electronics as part of your component order.

HARDWARE PACK 1

Qty 8	2-56 x 3/16" screws	
Qty 20	4-40 x 5/16" screws	
Qty 28	No. 4 internal lockwashers	
Qty 20	4-40 nuts	

HARDWARE PACK 2

Qty 8	4-40 x 3/16" screws	
Qty 8	6-32 x 1/4" screws	
Qty 8	No. 6 internal lockwashers	
Qty 18	No. 4 x 3/8" sht. metal screws	
Qty 8	Black No. 6 x 3/8" sht. metal screws	

II. Microphone Jack Considerations

Two 8-pin mic chassis jacks are included with your "semi-kit," and most modern transceivers (Kenwood, late Ten-Tec, Icom, Yaesu, Elecraft, Flex-Radio) will use these jacks. Older vintage rigs (early Ten-Tec, Drake TR-5/7, Johnson Ranger, Collins KWS-1, Heathkit, etc.) typically used either 4-pin or 2-pin connectors. The mic jacks for all of these vintage rigs also will fit in the 5/8 in. prepunched holes in the front panel, but must be supplied by the builder.

Some other vintage rigs, for example the Collins "S-Line", the Drake "B-Line" and "C-Line," and the National NCX-5, use 3/16 in. or 1/4 in. microphone plugs whose mating jacks require a 3/8 in. hole. If you want to use one of these microphone jacks, then you should use insulating washers (not supplied) to adapt each jack to the 5/8 in. hole in the StationPro's front panel. (Insulating washers will minimize hum pickup – see the next paragraph and **Appendix A: Avoiding Ground Loop Complications.**)



Any of these microphone jacks can be used with the StationPro, although the two on the left will require washers to clamp them to the 5/8" hole in the front panel

You can “mix and match” microphone jacks in the StationPro, e.g., using one 8-pin and one 4-pin jack. Also, you can easily configure the SP-I so that a microphone wired for, say, a forty-year-old Collins KWM-2 transceiver, can be used with a modern Elecraft K3 transceiver, even though the mic connectors are different. **Note, however, that vintage microphones using a single shielded cable to carry audio signals (as opposed to modern microphones having dedicated mic+ and mic- conductors) are particularly susceptible to hum caused by ground loop currents. Before installing jacks intended for such microphones (such as the 2-pin 5/8 in. jack – second from the right in the above photo), you should carefully read Appendix A: Avoiding Ground Loop Complications at the end of this manual**

III. Front Panel Assembly

Begin by identifying the SP-I front panel circuit board and collect all of the components, listed below. (Refer to the master parts list for additional details about each component, including their Mouser part numbers. Also, photos of most components are shown in the step-by-step directions that follow.)

<u>SP-I Front Panel Parts List</u>		
C301-C306	1000pF	Capacitor, 50V, qty 6
DS301- DS304	LED	Green LED, qty 4
DS306-DS308	LED	Yellow LED, qty 3
DS305	LED	Red LED, qty 1
--	LED bezels	LED mounting clips, qty 8
J301	Key Jack	1/4 in. Stereo NO Phone Jack, qty 1
J302	Phone Jack	1/4 in. Stereo NO/NC Phone Jack, qty 1
J303	Phone Jack	3.5 mm Stereo NO/NC Phone Jack, qty 1
K301	Relay	P&B/Tyco V23105, DPDT, qty 1
P301	Header	Molex 2x13 pin, 0.100 male header, qty 1
P302	Header	Molex 4-pin PCB connector w/locking clip, qty 1
R301	1000 Ω	Resistor, <u>1Watt</u> (brown-black-red), qty 1
R302-R304	2.2 KΩ	Resistor 5% carbon film 1/4W (red-red-red), qty 3
S301	Switch	Plastic DPDT paddle, qty 1
S302-S305	Switch	SPDT, min toggle, qty 4
hookup wire	5 ft (approx)	

Note that no component is needed for Header H301 on the rear of the circuit board; wires from the microphone jacks will solder directly to the pads of H301 in a subsequent step. Also note that headers P301 and P302 mount on the *rear* side of the board, as indicated on the silkscreening. All other components mount on the front side.

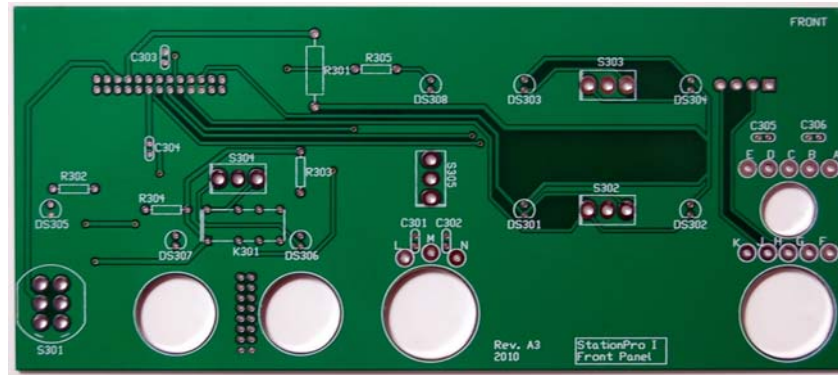

SP-I Front Panel Circuit Board –Front View



Principal SP-I Front Panel Components. Top row (left to right): K301, J302, J301, mic jack, S301. Bottom row: J303, S302-S305, LED, Led bezel

(1) Install the resistors onto the circuit board. Make certain the resistor bodies lie flat against the board before soldering and align all the resistor color codes in the same direction.

R301 1 K Ω (brown black red) This is a 1 Watt resistor.
 R302-R304 2.2 K Ω (red red red) These are 1/4 Watt resistors.

(2) Install the six blue epoxy-dipped capacitors onto the circuit board. Make sure you install the capacitors on the front side, as indicated by the silkscreening.

C301-C306 1000 pF (marked 102)

(3) Install relay K301 on the front side of the board. Make certain the relay body lies flat against the board. *Hint: solder diagonally opposite pins first, so you can readjust the relay body if necessary.*

(4) Install the 26-pin (2x13) header P301 and the 4-pin PCB connector w/locking clip P302 on the **rear** side of the circuit board. *Hint: solder the end pins first to secure the headers. After you're certain the headers are seated snugly against the board, with the pins perpendicular to the board, solder the remaining pins.*

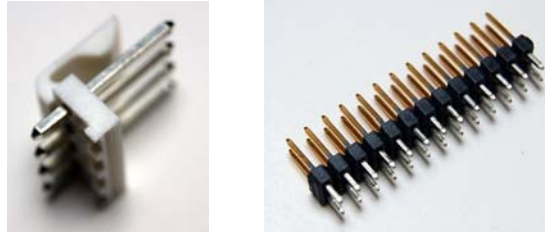

4 pin 0.156" male PCB connector with locking clip (P302) and 26 pin (2 x 13) male header (P301)

(5) Remove all hardware from the four SPDT miniature toggle switches and discard the flat washers. Finger tighten one of the nuts against each switch body and then temporarily secure each toggle switch to the front panel with the remaining nut and lockwasher. The lockwasher should be behind the panel, and the front panel nuts should also be only finger-tight. The switches mount in either direction.

(6) DO NOT attach the plastic DPDT AC power switch to the front panel. It will be installed later.

(7) Temporarily attach the circuit board to the front panel, adjusting the switches as necessary to make sure their pins fit into the mating holes on the circuit board. When you are certain the switch bodies are snug against the circuit board, solder all the switch pins to the circuit board. Be sure to use enough heat on the ground pins of the switches for the solder to flow and make a good connection to the backplane.

(8) Now detach the front panel from the circuit board, taking care not to lose the outer nut and lockwasher from each switch. Leave the inner nut in place.

(9) Mount the plastic DPDT AC power switch S301 on the front panel (it goes either way). The nut should be only finger tight. Now temporarily set aside the front panel.



AC Power Switch S301

(10) Referring to the photo on the previous page, identify all the jacks that mount on the front panel: two microphone jacks, the 1/4 in. key jack (J301), the 1/4 in. headphone jack (J302), and the 3.5mm headphone jack (J303). As illustrated below, bend the solder lugs

out flat on the key jack, so that they won't touch the printed circuit board when installed. Don't mix up the two 1/4 in. jacks; the J302 jack has an enclosed black plastic shell.



Bend the solder lugs on the key jack (J301) out flat, so they won't touch the front panel printed circuit board. If you're installing your own mic jacks with similar solder lugs, bend them out flat too.

(11) Solder a 5 inch length of hookup wire (approximately) to each pin on all jacks. (You will trim to size, later.) **Important:** when you solder the wires to the black 1/4 in. headphone jack (J302), orient the wires so they emerge from the side of each terminal rather than straight out the back. This will increase the rear clearance for this jack, which is tight when the front panel is installed in the cabinet. *Hint: a small length of sleeving or heat-shrink tubing slipped over each pin of multipin mic jacks will make a neat-looking job (not shown in below photo).*

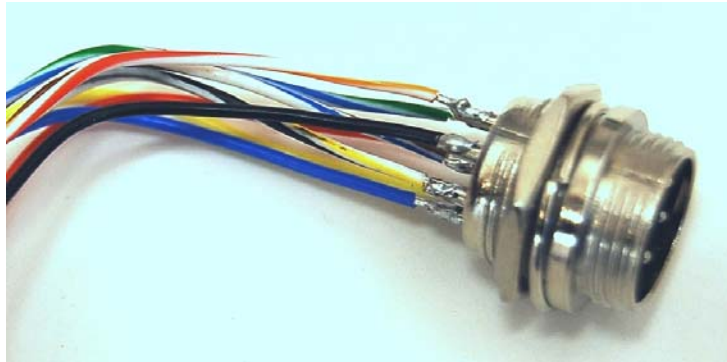

Different wire colors make it easy to keep track of microphone jack pin numbers. Otherwise, tag each wire, or use an ohmmeter to verify the pin numbers

(12) Loosely attach all the jacks to the front panel and then secure the printed circuit board to the front panel with the toggle switch hardware. If necessary, adjust the AC power switch so that its pins fit into their mating circuit board holes. As before, there should be a nut and lockwasher *behind* the panel for each of the miniature toggle switches. Feed all the jack wires through the access holes in the circuit board, as shown in the two photos below.

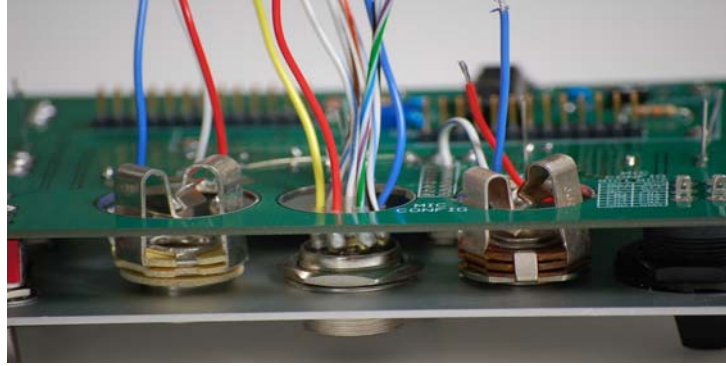

Detail showing wires from jacks threaded through the access holes on the front panel printed circuit board. Be sure none of the wires interferes with the jacks' operation

(13) Make sure none of the jack wiring interferes with the insertion of plugs. If you have provided your own 1/4" or 3/16" microphone jacks, be certain that their tabs do not touch the rim of the circuit board access holes. You'll need to insert a plug into the jacks to verify adequate clearance, since the plugs bend the tabs out slightly. If any tabs touch the hole rims, then file the hole rim with a small needle file to provide clearance. (No filing will be necessary if you use the supplied 8-pin mic jacks, or other jacks that fit the 0.625" front panel holes.)

(14) Rotate the jacks so that their wires are oriented adjacent to the matching lettered pads on the circuit board. The indent on 8-pin microphone jacks should face downward, and the washer should be *behind* the panel. Flat washers on 1/4 in. jacks go in *front* of the panel. There are no washers on the 3.5 mm headphone jack. Note that the clearance behind the black plastic 1/4 in. headphone jack will be tight once the front panel is installed, so do not use a second nut behind the panel on the jack. Now tighten all the jacks to the front panel, and also tighten the plastic nut on the AC power switch. Take care not to scratch the panel.

(15) Solder the pins on the plastic AC power switch S301 to the circuit board.

(16) Trim the wires from the headphone jacks (J302 and J303) and key jack (J301) to size (no longer than necessary), tin their ends and, referring to the drawings and tables below, solder them to their mating pads on the circuit board. If you prefer, you can route the wires from the 3.5 mm phone jack (J303) around the edge of the circuit board, rather

than through the access hole. **IMPORTANT:** double-check to make sure you have identified all the wires correctly.



Trim the wires to size (keep them as short as practical) and solder each to its mating pad on the circuit board. If color-coded wires are not used, verify pin connections with an ohmmeter. Instructions for wiring the mic jacks shown above are given in Step (17), below.

3.5 mm Headphone Jack Pins (J303)

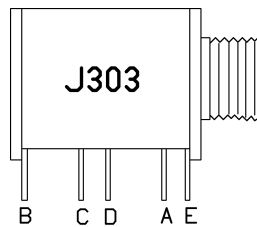

- A Tip
- B Tip (norm. closed contact)
- C Ring
- D Ring (norm. closed contact)
- E Common (ground)

1/4" Headphone Jack Pins (J302)

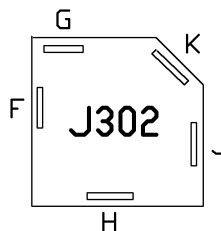

- F Tip
- G Tip (norm. closed contact)
- H Ring
- J Ring (norm. closed contact)

K Common (ground)

Key/Paddle Pads J301 (no drawing shown)

L Tip (dot)
M Ring (dash)
N Common (ground)

(17) Microphone Jack Wiring: The microphone wiring table silkscreened onto the rear of the circuit board corresponds to the sixteen pads of H301 that are centered between the two microphone access holes (see photo).

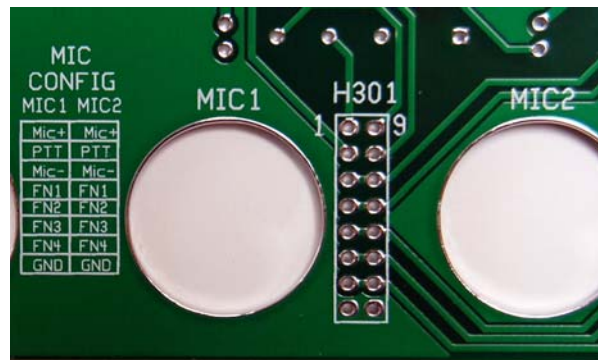

Although some microphones have numerous features (UP, DOWN, etc.), at a minimum nearly all have at least three wires: an audio output wire (Mic+), a PTT wire; and a ground (shield) wire. If a microphone jack has a separate “Mic Gnd” or “Mic-” wire, then connect it to the Mic- pad and not to GND..

Note that there are four rows of pads labeled FN1-FN4 on the silkscreened table. These pads, along with the Mic- pads, differ from the Mic+ and PTT pads because both pads in each row, FN1 for example, are jumpered together on the circuit board. You can assign the other microphone wires (e.g., UP, DOWN, +V, etc.) to FN1-4, in any order you like, but be sure to assign the corresponding wires on each microphone to the same pads. In other words, if you assign FAST to FN1 for Microphone 1, then you should also assign FAST to FN1 for Microphone 2. The following table shows recommended pad assignments for common 8-pin microphone pinouts used in contemporary transceivers.

IMPORTANT: if you do not use any of the FN1-4 rows, then jumper an unused pad on that row to the GND pad. However, if a pad, such as FN4, is used only on one microphone but not on the other, then do NOT ground the unused FN4 pad. Now trim the wires from each microphone jack to size, tin the ends, and solder each wire to its pad, according to the table. Be especially careful to avoid short circuits from loose wire strands or solder bridges on the Mic+ pads (Pin nos. 1,9) and PTT pads (Pin nos. 2,10).

Common 8-pin Microphone Pinout Table

PCB Pad Label	-----Mic Connector Pin No .-----				
	Elecraft	Yaesu	Ten-Tec	Icom	Kenwood
MIC+(Audio Out)	1	8	8	8	1
PTT	2	6	6	5	2
MIC- (MIC GND)	7	7	7	7	7
FN1 (FAST)	5	4	--	--	--
FN2 (DOWN)	4	3	--	--	3
FN3 (+V)	6	2	2	2	5
FN4 (UP)	3	1	--	3	4
GND	8	5	5	6	8

(18) Once you have soldered all the wires from the front panel jacks to their mating circuit board pads, carefully inspect your work to make sure there are no short circuits, solder bridges, or unsoldered connections.

(19) Slide four green LEDs through the front panel LED cutout holes on the panel so that their leads pass into the mating holes on the circuit board marked DS301, DS302, DS303, and DS304. Do not solder the LEDs yet. **IMPORTANT: The flat side of the LEDs (the short wire) goes down, as indicated on the silkscreened legend.**

(20) Similarly, insert three yellow LEDs into DS306, DS307, and DS308. Do not solder the LEDs, and be sure the flat side is down.

(21) Insert a red LED into DS301 (flat side down). Do not solder the LED.

(22) Snap the LED plastic mounting bezels into their cutouts on the front panel, taking care not to let any of the LED leads slip out of their circuit board pads.

(23) Slide the body of the LEDs into the back of the LED bezels until they click into place. Use a small flat-blade screwdriver to nudge the LEDs into the bezels. Once you have verified that each LED is seated in its bezel, and that each bezel is pushed flat against the panel, solder all the LEDs to the circuit board. *Hint: if you have trouble getting the LEDs to snap into the bezels, try bending the plastic tabs on the bezels out slightly, using a small-bladed screwdriver.*

(24) Clean the flux from the rear of the circuit board with isopropyl alcohol and Q-tips and then inspect each solder connection using a magnifying glass. Pay particular attention to the grounds on the LEDs and switches; make sure solder has flowed onto the groundplane and isn't beading up on the pad.

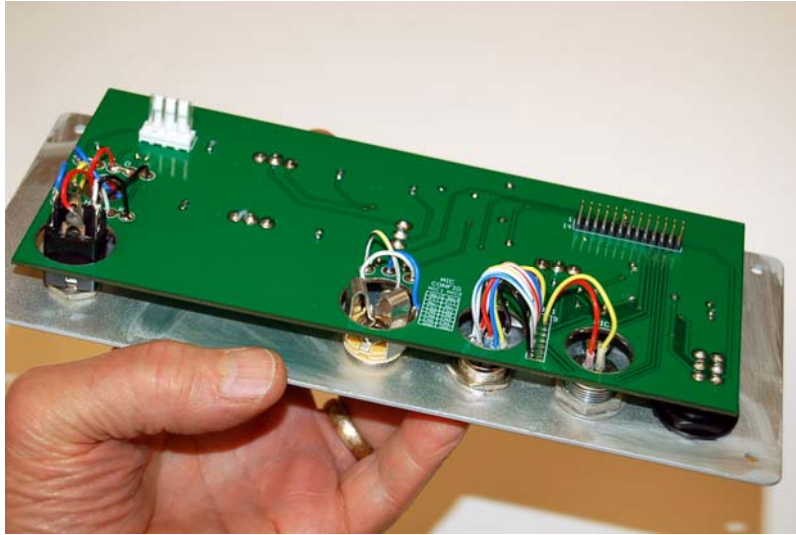

Be sure to inspect all the solder connections after assembly. Make certain none of the solder lugs on the front panel jacks are touching the circuit board.



(25) Set aside the completed front panel assembly.

IV. Main Circuit Board Assembly

Identify the small jumper circuit board and the large main circuit board, both pictured below, and collect all of the components in the following list. (Refer to the master parts list for additional details about each component.) Note that all components will install on the *top* side of the circuit board.

Main Circuit Board Parts List

C101	0.1 μ F	Capacitor 50V epoxy dipped ceramic, qty 1
D101–D107, D109	1N4005	1A/600PIV diode, qty 8
F101	Fuse Clips	PCB mount fuse clips, qty 2

F101	Fuse	Fuse 1Amp 3AG, qty 1
J101-J104	Connector	Molex 0.156" 12-pin top-entry female header, qty 4
J101-J104	Jumper Header	Molex 0.156" 12 pin male header, qty 4
J105, J106	Connector	Molex 0.156" 4-pin top-entry female header, qty 2
J105-J106	Jumper Header	Molex 0.156" 4 pin male header, qty 2
J107	Connector	2.5mm DC pwr jack, PCB side entry, qty 1
J108, J109	Connector	D-Sub 25 pin male, PCB side entry, qty 2
J110	Connector	D-Sub 9 pin female, PCB side entry, qty 1
J111	Connector	DIN 5 pin female PCB side-entry, qty 1
J112	Connector	RJ45 8pin PCB side-entry, qty 1
K101-K113	Relay	P&B/Tyco V23105, DPDT, qty 13
K114	SS Relay	Clare Optomos PLA140 solid state relay, qty 1
P101, P103	Connector	Molex 2x13 pin, 0.100" male header, qty 2
P102	Connector	Molex 4-pin 0.156" PCB male w/locking clip, qty 1
Q101	2N3906	PNP gen purpose transistor, qty 1
R102, R103	2.2 K Ω	Resistor, 5% carbon film, 1/4W (red-red-red), qty 2
R104, R105, R106	1 K Ω	Resistor, 5% carbon film 1/4W (brown-black-red), qty 3

***** Parts for optional amp relay keying circuit (delete K114, R106 if used) *****

(R101)	4.7 K Ω	Resistor, 5% carbon film 1/4W (yellow-violet-red), qty 1
(D108)	1N4005	1A diode, qty 1
(Q102)	IRF610PBF	MOSFET power transistor, qty 1

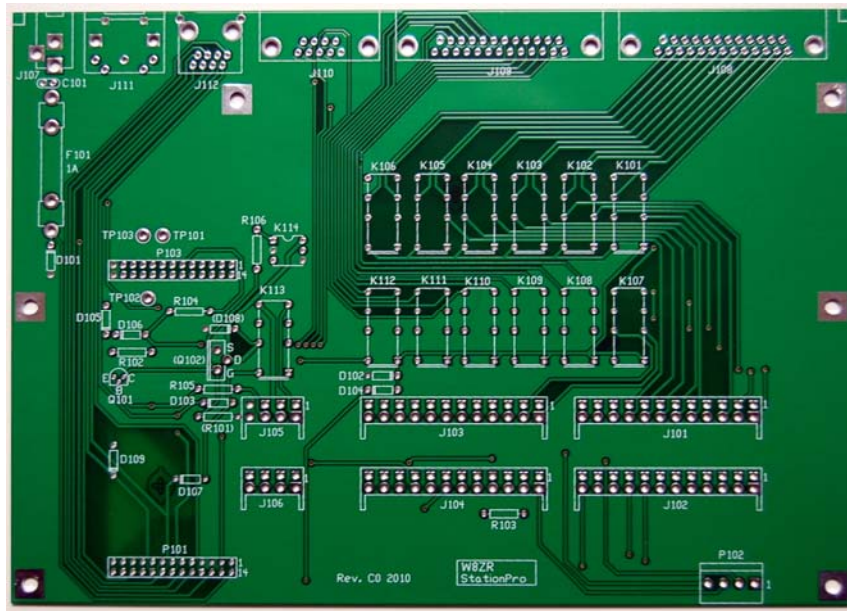

Main Printed Circuit Board (Top View)



Jumper Circuit board (Top View)

(1) The main circuit board has provisions for a “default” amplifier keying circuit, and an “alternate” amplifier keying circuit, and the builder must choose which circuit to use. The default circuit (rated at 400V @ 250 mA, AC or DC of either polarity) is recommended for nearly all applications. The alternate circuit (rated at 3.5A, 200V, positive polarity only), should only be used for keying very high current, positive voltage DC relays. **CHOOSE ONLY ONE CIRCUIT!** Now install the selected components, as illustrated below:



Note the white dot on K114. Be sure to get the orientation right when you install this component.

Default Amp Keying Circuit: Install K114 and R106 (brown-black-red). Make sure the notch on K114 is aligned with the notch on the silk-screened outline. Note the white dot near pin 1. K114 looks like a 6-pin IC.



R101, D108, and Q102 should NOT be installed if the default keying circuit is selected.

Alternate Amp Keying Circuit: Install D108, Q102 and R101 (yellow-violet-red). Match the band on D108 to the circuit board pattern, and bend the leads on Q102 so they line up with the holes in the circuit board. Position Q102 about

1/4 in. above the board. Note that the silkscreened component IDs for these parts are in parentheses.

(2) Install the remaining 1/4 watt resistors, making sure the resistor bodies are flat against the circuit board and that color codes are aligned in the same direction:

R102, R103	2.2 K Ω (red-red-red)
R104, R105	1 K Ω (brown-black-red)

(3) Install 1N4005 diodes at D101-D107, and D109, and a 0.1 μ F blue dipped epoxy capacitor at C101. Make sure the diodes bands are oriented as shown on the silkscreened legends, and take care not to confuse the value of the capacitor with others that look the same. A “104” marking indicates a 0.1 μ F value.

(4) Install the 2N3906 transistor Q101, taking care to get the orientation correct. Bend the leads to align them with the holes on the circuit board. The transistor should sit about 1/4” above the board.

(5) Install the thirteen relays K101-K113. Begin by soldering two opposing pins on each relay so you can make sure the relay bodies seat flat against the circuit board. Then solder the remaining pins. Solder these one at a time, or you’ll never get them positioned properly.



Be certain not to miss any pins when you solder the thirteen relays to the circuit board

(6) Referring to the photos below, identify the four 12-pin Molex female connectors you will install at J101-J104 and the two 4-pin Molex female connectors to be installed at J105 and J106. Now identify the 12 pin and 4 pin straight male headers whose pins will mate with these connectors.



12 pin Molex 0.156” female PCB connector and matching 12 pin header

As shown below, push a header into each of the six connectors (long pins go into the connector), making sure the headers are seated fully into the connectors. To ensure proper alignment, set the small jumper circuit board onto the headers, so that their short pins fit snugly against the jumper board. and then solder the pins to the jumper board.

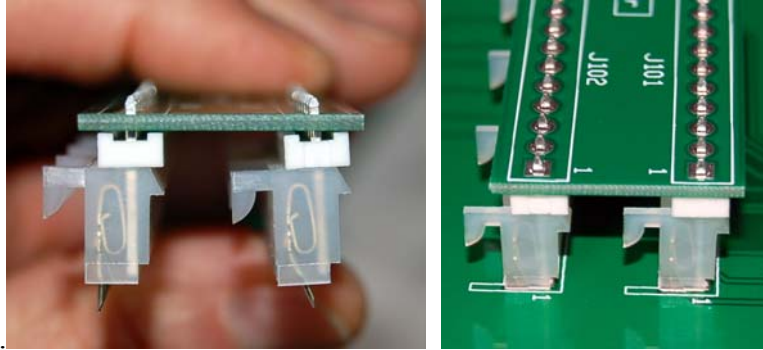

Pre-installing the jumper board and its male header pins will ensure proper alignment and positioning of J101-J106 on the main circuit board.

Now solder the pins of all six Molex connectors to the main circuit board (56 pins in all). **Be sure you orient the connectors to match the silkscreened outline on the circuit board, and be sure the connector pins go into the round holes in the circuit board and not the square holes.** When you're done, leave the jumper board in place. (*Hint: Solder one end pin on the block of connectors first, so you can make certain the connector bodies are seated flat against the main circuit board, as shown above. Then solder the remaining pins.*)

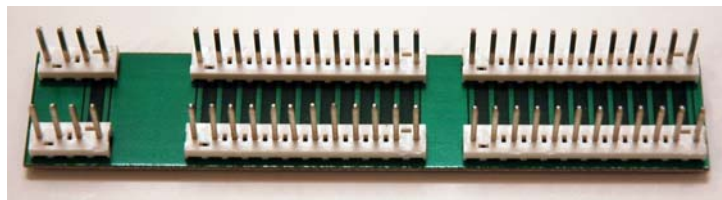

The jumper will be removed and replaced by a microcontroller circuit board when an SP-I is upgraded to an SP-II.

(7) Install the Molex 0.156" 4-pin male connector (with locking clip) at P102.



The Molex 0.156" male connector with locking clip installs at P102.

(8) Install the fuse clips at F1. (*Hint: Before installing the clips, insert the 1A fuse into the clips to hold them in place and to make sure you don't install the clips backwards.*)



Install the 1A fuse into the fuse clips before soldering them to the circuit board.

(9) Install the two 26 pin (2x13) male headers at P101 and P103. Solder two end pins first on each header to make certain the body of the header is flat against the circuit board. Then solder the remaining pins. Clean off the flux with alcohol and then check the solder joints with a magnifying glass to make sure there are no solder bridges between pins.



26 pin male headers install at P101 and P103.

(10) Install the six connectors J107-J112 along the rear edge of the circuit board. (See photo, below.) Make absolutely certain the connectors are seated flat against the board before soldering the pins; otherwise, they won't fit properly into their rear panel cutouts. As before, inspect each solder joint with a magnifying glass to look for cold solder joints and solder bridges. Some of the connectors have metal mounting tabs, and these should be soldered to the ground plane on the circuit board. *Hint: It takes extra heat to solder pins and tabs to the ground plane of the circuit board. Be sure to use a large enough soldering iron and make certain that solder has flowed onto the ground plane.*

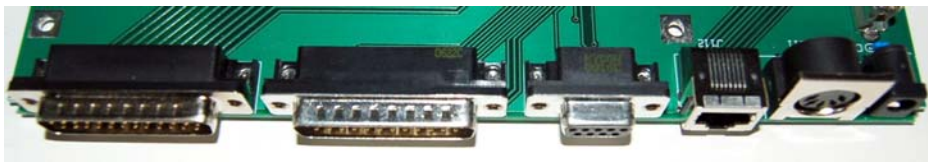

From left to right, J108, J109, J110, J112, J111, J107

(11) Clean the flux from the circuit board with isopropyl alcohol and Q-tips and then inspect each solder joint using a magnifying glass. Look especially closely at the multipin connectors along the rear edge of the circuit board and the two 26 pin headers.

(12) With a pair of wire cutters, cut out 1/8" notches at each rear corner of the circuit board. Note that the outline of the notches is silkscreened on the board. These notches allow the circuit board to clear the side brackets on the enclosure.

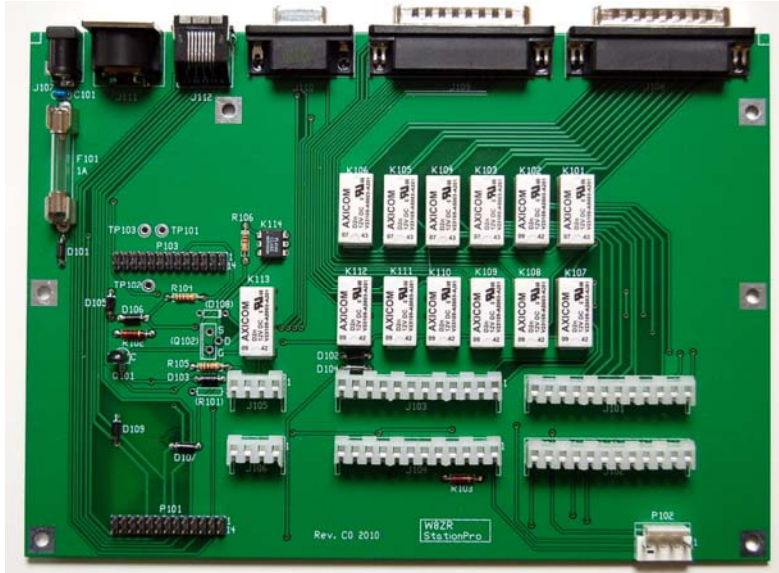

Note the notch cutouts silkscreened on the rear corners of the main printed circuit board

(13) Install No.6 x 1/2" threaded standoffs at the six locations (five along the sides, and one behind J112, the 8-pin RJ45 jack) on the bottom side of the circuit board. Use a 6-32 x 1/4" machine screw and a #6 internal lockwasher under each screw head. Tighten the screws securely.

(14) Plug six inch 26-conductor flat ribbon cables into headers P101 and P103. As shown below, orient the cables so that one flat cable emerges out of header P101 toward the front edge of the circuit board, while the cable from P103 points toward the rear edge of the circuit board. **Important: Check closely to make certain the connectors are aligned properly with their mating pins on the headers, and are not inadvertently offset.** Leave the other ends of the cables free.

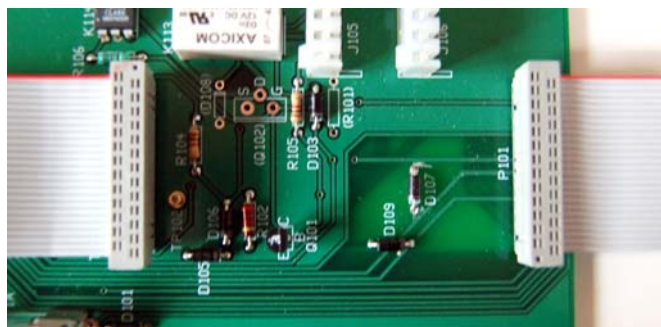

Be certain the ribbon cables are not not accidentally offset from the pins in their mating connectors

(15) Set aside the completed main circuit board. Note that if you selected the default amplifier keying circuit, then no components are installed at (R101), (Q102), and (D108).

V. Rear Panel Circuit Board Assembly

Identify the rear panel circuit board and the components in the following list. All components mount on the top side of the printed circuit board.

Rear Circuit Board Components

C401-C419	1000 pF	Capacitor, 200V, qty 19
C420	0.1 μ F	Capacitor, 50V, qty 1
J401	Connector	1/4 in 2-circuit PCB phone jack, qty 1
J402	Connector	3.5 mm 1-circuit PCB phone jack, qty 1
J403	Connector	3.5 mm 2-circuit PCB phone jack, qty 1
J404, J405	Connector	triple RCA phono jack (R/Wh/Ye), qty 2
J406-J409	Connector	dual RCA phono jack (R/Wh), qty 4
J410	Connector	2.5 mm DC pwr jack, PCB side entry, qty 1
P403	Header	Molex 26 pin (2x13, 0.100" male header, qty 1

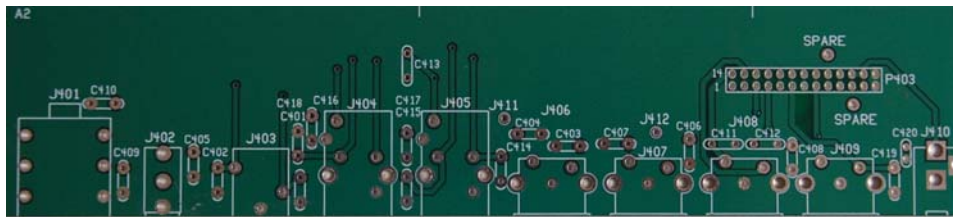

Rear Panel Circuit Board

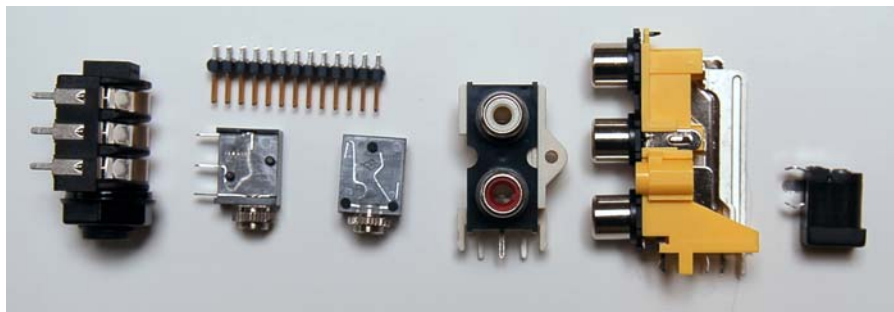

Rear Panel Circuit Board Components (left to right): J401, J403, J402, J406-J409, J404-J405, and J410. The 26 pin (2 x 13) header is P403.

(1) Install capacitors C401-C419 (1000 pF/200V) capacitors. Note that one pin of each capacitor solders to the ground plane, so be sure to use enough heat for the solder to flow. Then install C420 (0.1 μ F/50V), which is next to J410 on the right side of the board. Note that the 1000pF/200V capacitors have a yellow boxy shape (marked 102), while the 0.1 μ F/50V is blue and marked 104.

(2) Install the 26 pin (2x13 pin) male header at P403. Solder diagonally opposite pins first, to make sure the header is flush against the board.

(3) Install connectors J401-J403, and J410. Make sure each connector is seated flat against the circuit board. This is very important, because any misalignment will keep the circuit board assembly from fitting properly in its mating holes on the rear panel. If any of the pins on J410 (the power jack) are too tight to fit into the circuit board pads, then trim the pins as necessary with wire cutters.

(4) Install the triple RCA phono jacks at J404 and J405, and the double RCA phono jacks at J406-J409. Again, take care to ensure that the jacks are seated snugly on the circuit board. They should mount perfectly flush onto the board, and not tilt or lean in any direction.

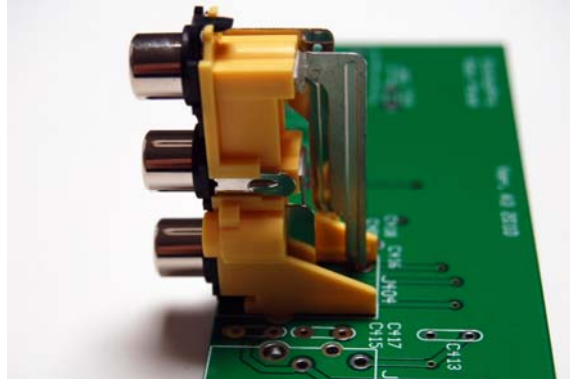

Be certain the modular RCA phono jacks are seated flush on the circuit board before you solder their pins. Otherwise the jacks won't fit into the cutouts on the rear panel.

(5) Clean and inspect all solder connections. Note that there are three unused pads, labeled “J411”, “J412”, and “SPARE.” J411 and J412 are in parallel with two of the RCA Phono jacks (J406 and J407, respectively) and can be used if builders wish to add other types of connectors to the rear panel (e.g., banana jacks or terminal strips). When you're done, set aside the completed rear panel circuit board.

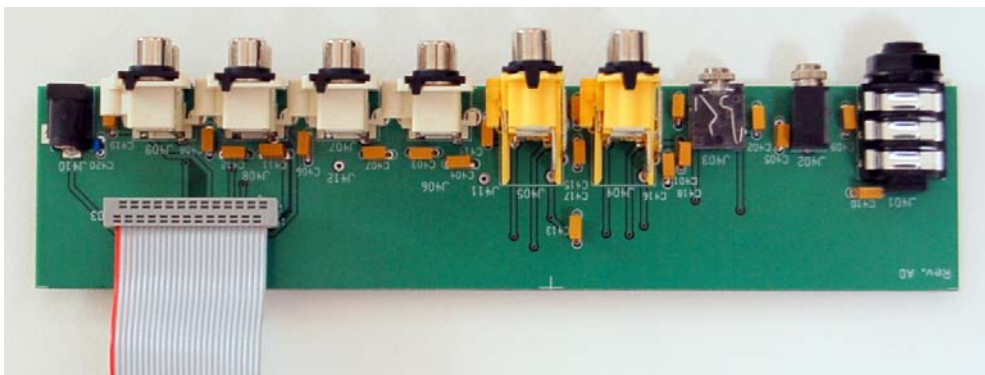

Completed rear panel circuit Board, For future reference note the orientation of the ribbon cable (which has not yet been installed)

VI. Final Assembly of the SP-I Controller

(1) Identify the small (4.5" x 0.75") blank metal cover plate (supplied with the semi-kit), and as shown in the following photo secure it to the inside of the rear panel so that it covers the unused cutouts for the DB25 connector (TX/RX-3) and the two RJ25 connectors (REM IN and REM OUT). Use three No. 4 x 3/8" sheet metal screws, and orient the cover plate so that the smooth side of the three drilled holes is against the rear panel. This cover plate will be removed if the SP-I is subsequently upgraded to an SP-II.

(2) Attach the main circuit board to the rear panel, using the six jack screws that secure the two 25-pin DB25 connectors and the 9-pin DB9 connector. Before you tighten the jack screws, make sure the body of the 8-pin RJ-45 connector (RELAY/CTRL) fits into its rectangular cutout on the panel. The jack screws are fragile, so do not overtighten them.



*The main circuit board attaches to the rear panel with six jack screws.
Note also how the blankoff cover plate attaches with three sheet metal
No.4 x 3/8" sheet metal screws.*

(3) Attach the rear panel circuit board to the rear panel, using six No. 4 x 3/8" sheet metal screws and the nuts on the Key, Line In and Line Out jacks. Make certain that the RCA phono jacks are properly centered in their holes on the panel before you tighten the sheet metal screws. Note that the black plastic washer on the key jack goes under the nut on the outside of the panel.



*The rear panel circuit board attaches to the rear panel with six No. 4 x
3/8" sheet metal screws and the nuts on the jacks.*

(4) As shown below, attach the left and right side enclosure brackets to the rear panel, using the 6-32 x 3/8" screws supplied with the enclosure (not with the hardware packs). Do not use any washers. Note that the lip on the side brackets will fit into the notches previously cut into the main circuit board.

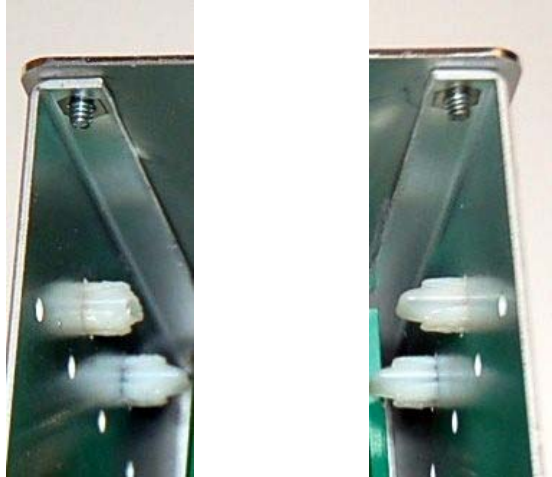

(5) In the same manner, attach the front panel assembly to the left and right side brackets. Use the four black 6-32 x 3/8" machine screws supplied with the enclosure, with no washers. **NOTE: When you attach the front panel to the side brackets, inspect carefully the lugs on the back of the 1/4 in. headphone jack to make sure they don't bump into the 4-pin Molex header at P102 on the main PCB. If they do, carefully bend the interfering lugs out of the way. These lugs are brittle, so bend them slowly (to allow stresses to equalize), no more than necessary, and avoid sharp bends.**

(6) Press four adhesive-backed feet onto the underside of the bottom cover (Note that the bottom cover is the one that has two small holes punched in it)

(7) Attach the bottom cover to the side brackets, using the black No.10 self-tapping screws supplied with the enclosure, and secure the two front-most threaded standoffs on the main circuit board to the bottom cover, using 6-32 x 3/8 machine screws and No. 6 internal lockwashers. The lockwashers go underneath the screw heads. The remaining four standoffs are not attached to the bottom cover.

(9) Plug the free end of the previously installed 26-conductor ribbon cable from P101 on the main circuit board to P301 on the front panel circuit board. When properly installed, the cable should not twist. Don't forget to check the alignment of the ribbon cable with the pins on P301, to make sure they are not inadvertently offset.

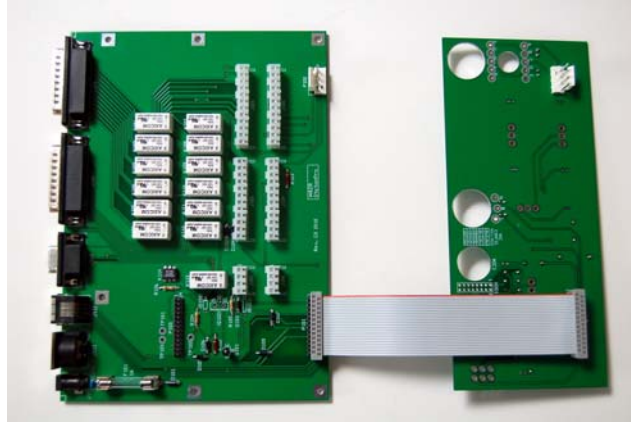

When properly installed, none of the ribbon cables should be twisted and all should line up nicely with their mating headers.

(10) In the same way, plug the free end of the ribbon cable coming from P103 on the main circuit board into P403 on the rear panel circuit board. The cable should not be twisted. Again, make sure none of the ribbon cable pins are offset from those on the mating connector. At this stage of the assembly, both ribbon cables should be installed.

(11) Following the steps below, prepare and install a short 4-conductor cable assembly to connect from P102 on the main circuit board to P302 on the front panel circuit board.

(a) Cut four 6 inch lengths of 22 AWG stranded hookup wire, and strip each end about 3/16 inch. If available, it will be convenient to use different color wires.

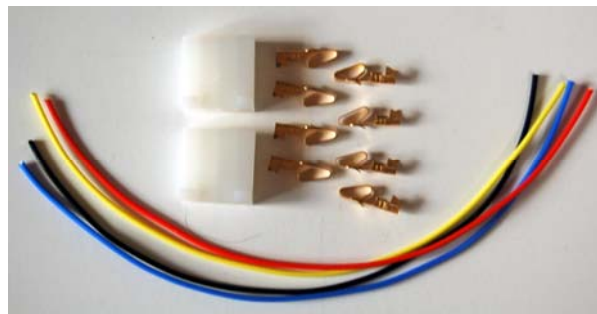

(b) As shown above, identify two 4-pin Molex 0.156" nylon connector housings (Mouser p/n 538-09-50-3041) and eight crimp terminals (Mouser p/n 538-08-50-0134). Using needle-nose pliers, crimp a terminal onto each end of the hookup wires prepared in the previous step. (*Hint: it's a good idea also to solder the wires to the terminals. Use the smallest amount of solder necessary for a good connection.*)

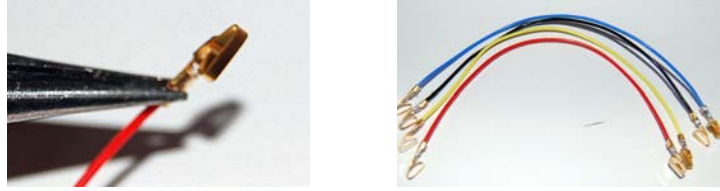

(c) Snap the terminals into each connector housing. Use a small flat-bladed screwdriver to push each terminal into the housing. The terminals only insert one way and will click into place. Be sure you're inserting the terminals into their correct hole on the housing, because once installed they are difficult to remove.

Important: Make sure the wires don't cross, i.e., pin 1 on one housing should mate with pin 1 on the other housing. Note that pin 1 is identified on the silkscreened legends.



(d) Plug one end of the cable assembly into P102 on the main circuit board, and the other end into P302 on the front panel circuit board. Again, be sure not to cross the wires.



One end of the prepared cable plugs into P302 on the front panel circuit board.

(12) Attach the top cover to the enclosure, using the black No.10 self-tapping screws supplied with the enclosure. This completes the assembly of the StationPro I control unit.

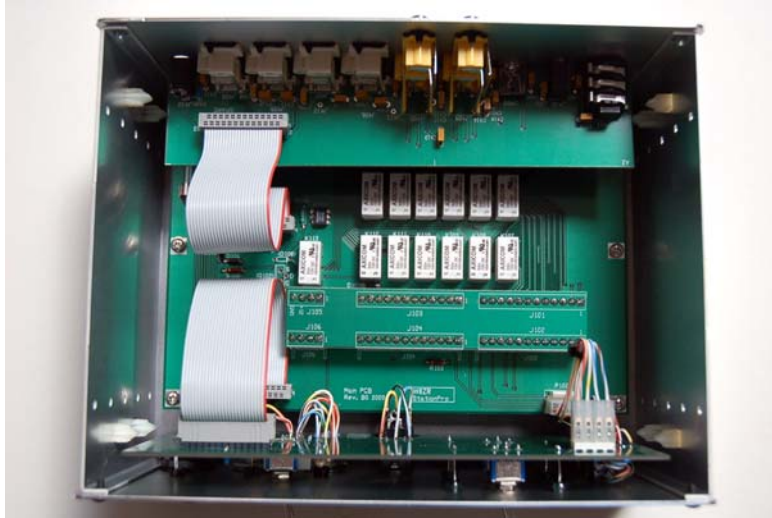

Interior view of completed SP-I Controller

VII. RF Relay Unit Assembly

Preparation for Assembly: The RF relay enclosure shown below consists of two interlocking aluminum pieces powder-coated with an extremely durable graphite-colored finish. Unfortunately, the powder-coating process has an unavoidable overspray into the interior of the enclosure. Before beginning assembly, therefore, the builder should use the small strip of emory cloth provided with the hardware packs to sand the powder-coating off all the screw holes on the *inside* of the top cover. Doing so will ensure good electrical contact between the metal cover and the ten SO-239 coax jacks, and also between the metal cover and the four threaded standoffs that secure the printed circuit board. It is a good idea, but not strictly necessary, also to sand off the paint on the lip of the top cover, where the black sheet metal screws secure the two parts of the enclosure together.



(1) Identify the top cover of the RF relay enclosure and mount ten SO-239 UHF coax jacks to the inside surface, as shown below. Use two 4-40 x 5/16" machine screws, with internal lockwashers and nuts on each of the SO-239 connectors. The lockwashers go

under the nuts. There is a slight bit of wiggle room in the mounting holes, so use it to line up the connectors so their sides are parallel to one another.



(2) Mount four 4-40 x 1/4" threaded standoffs on the corner holes of the inside top cover, as shown above. Use 4-40 x 3/16" machine screws, with internal lockwashers under the standoffs (i.e., between the standoffs and the enclosure, not under the screw heads.)

(3) Identify the RF relay circuit board and collect the components that mount on the board, listed below. If necessary, refer to the master parts list for more details about each component.

RF Relay Circuit Board Components

J501	Connector	RJ-45 8 pin, top entry, shielded, PCB jack, qty 1
K501-K510	Relay	Tyco/Schrack RTB14012F SPDT 12A, qty 10
C501-C507	0.01 μ F	Capacitor 50V blue epoxy dipped ceramic, qty 7
C508	0.1 μ F	Capacitor 50V blue epoxy dipped ceramic, qty 1
D501-D507	1N914A	Si gen. purpose signal diode, qty 7

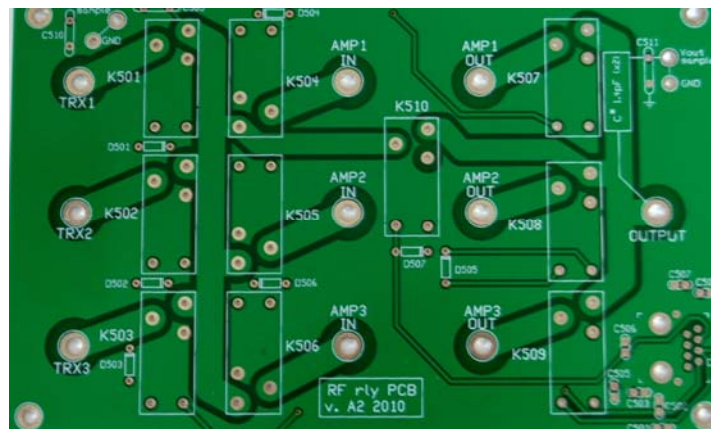

RF Relay Circuit Board (Top View)

(4) Plug J501, the 8-pin RJ-45 connector, into its mounting holes on the rear side of the circuit board, but do not solder the pins yet.

- (5) Temporarily mount the RF relay circuit board onto the inside of the top cover, making sure the center pin of each SO-239 jack extends into its mating hole on the circuit board, and that the body of J501 fits through the rectangular cutout on the cover. Loosely secure the circuit board to the four corner standoffs with 4-40 x 3/16" screws in order to verify that the holes line up. Once you're sure everything fits together properly, solder the pins on J501. Do not solder the pins yet on the coax jacks. Now unscrew the four 4-40 x 3/16" screws that you just installed, and remove the circuit board from the enclosure.
- (6) In the following steps, all components mount on the top of the circuit board. Install a 0.01 $\mu\text{F}/50\text{V}$ (marked 103) blue epoxy coated ceramic capacitor at C501-C507.
- (7) Install a 0.1 $\mu\text{F}/50\text{V}$ (marked 104) blue epoxy coated ceramic capacitor at C508.
- (8) Install 1N914A diodes at D501-D507, taking care to observe the diode polarity. The banded end of the diodes is indicated on the silkscreened legend.
- (9) Install RF power relays K501– K510. Install these one at a time and make sure the body of each relay is flush against the circuit board before you solder the pins.
- (10) OPTIONAL STEP. The printed circuit board has provisions for sampling the RF output from your transceivers and linear amplifiers. Most builders will probably not need this feature and can omit this step. Note that implementing the RF sampling feature will require drilling or punching two holes in the RF enclosure in order to mount two BNC coax jacks. (If desired, users can substitute two RCA phono jacks).

Necessary parts (to be supplied by builder):

BNC Chassis Jacks, qty 2
 Capacitor, 15 pF/500V (dipped silver mica), qty 1
 Capacitor, 330 pF/ 500V (dipped silver mica), qty 2
 Hookup wire or bare tinned wire: 6 in. (approx)

(a) Install the following capacitors:

C509 15 pF/500V, qty 1
 C510, C511 330 pF/ 500V, qty 2

(b) Note that the circuit diagram shows a high voltage capacitor C* which is part of the capacitive voltage divider that samples the RF from the selected amplifier. This capacitor is built into the circuit board copper pattern and has a value of 2.8 pF. Physically, this capacitor consists of two copper pads, each having a capacitance of 1.4 pF and connected in parallel by a copper trace. If in very high power applications it is observed that the sampled voltage is too great, this capacitor can be reduced to 1.4 pF by cutting the connecting trace.

(c) Drill or punch two 3/8" holes (for BNC jacks) at a convenient location on the opposing sides of the enclosure, near the RF pickoff points (see photograph below), and mount the BNC chassis jacks in the holes.

(d) Connect the BNC jacks to the sample pickoff pads on the circuit board, using a short length of hookup wire or bare tinned wire. Also ground the coax jacks to the ground pads on the circuit board, using another short piece of wire. This completes the optional step.

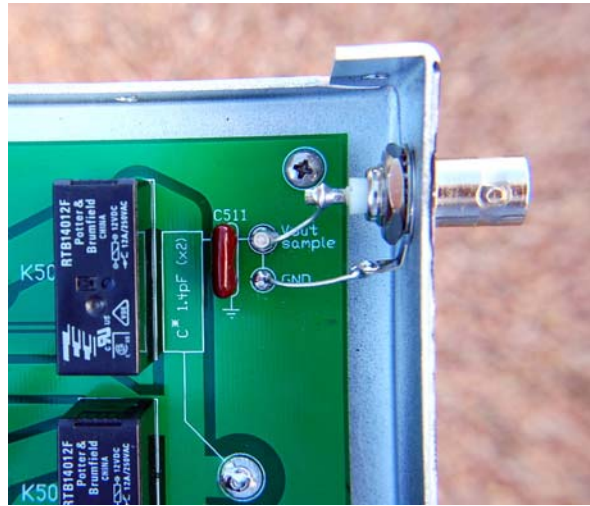

The RF relay unit, showing the optional RF sampling circuit, with side-mounted BNC connector.

(11) Secure the RF circuit board to the four standoffs on the inside top cover of the enclosure, using 4-40 x 3/16" machine screws and internal lockwashers. Place the lockwashers between the standoffs and the bottom of the circuit board (NOT under the screw heads). (*Hint: balance the lockwashers on top of the standoffs and carefully lower the circuit board with the screws dangling in each corner onto the standoffs.*)

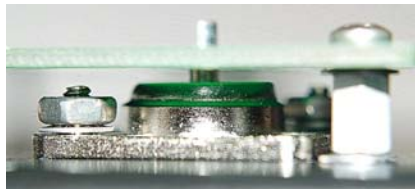

Lockwashers go between the standoffs and the circuit board and enclosure lid, not under the screwheads. The lockwashers ensure a good electrical connection between the circuit board ground plane and the enclosure lid, and also increase the clearance between the bottom of the circuit board and the SO-239 connector bodies. Note that the lockwashers on the SO-239 jacks go under the nuts.

(12) Make sure all the hardware securing the ten SO-239 jacks is tight, and then solder all ten center pins of the SO-239 connectors to the circuit board pads. Use enough heat to make certain the solder flows nicely, but use no more solder than necessary for a good connection. (You'll have to unsolder these pins if you ever want to remove the circuit board, so don't make the job harder by using too much solder!)

(13) Attach the cover to the RF relay enclosure using eight No.6 x 3/8" black sheet metal screws. This completes the assembly of the RF relay unit.



The completed StationPro RF relay unit

VIII. Transceiver Pod Assembly (Two Required)

Each transceiver (or receiver/transmitter pair) connects to the StationPro control unit via a single 25-wire computer-type serial cable. The free end of this cable terminates in a "pod," which is a small breakout box. Short cables go from this breakout box to the jacks (microphone, key, data, etc.) on the rear and front panels of the transceiver.

Modern transceivers have many different jacks, some of which may not be needed by all users. For example, most amateurs will use the microphone and key jacks, but many will not use the band data, packet, and transverter jacks. The below photograph shows the pod for a vintage National NCX-5 transceiver, which uses only a few breakout connections. At the other extreme, the pod for an Icom 7800 transceiver used in a contest station might use most of the 24 control lines. Thus, builders must decide not only what radios they will control with the StationPro, but also what features of those radios they wish to use.

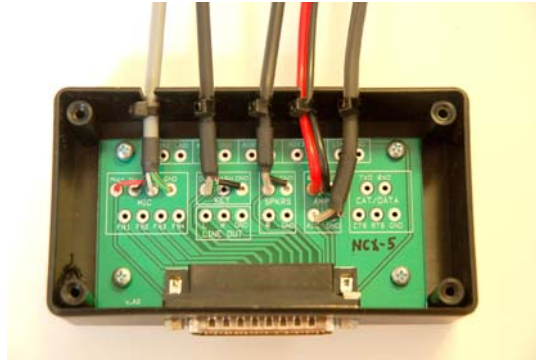

(1) Making a Connector List: Before starting to assemble your pods, you should make a table that lists the connectors you wish to use on your transceivers. The table should show the mapping between pin numbers on the transceiver jacks and the pads on the pod circuit board. Remember, you can always add connectors and features at any time as your interests change. Here is a sample connector list for an Elecraft K3 transceiver:

Elecraft K3 Pod Pinout Listing

A. Microphone Jack

Connector Type: 8 pin DIN

Conn. Pin #	Pod
6	FN3 (+8)
5	FN1 (function)
4	FN2 (DOWN)
3	FN4 (UP)
8	GND
2	PTT
7	MIC- (GND)
1	MIC+

B. CAT/DATA Jack

Connector Type DSUB DB-9

Conn. Pin #	Pod
1	N/C
2	RXD (ser out)
3	TXD (ser in)
4	N/C
5	GND
6	N/C
7	N/C(RTS)
8	N/C(CTS)
9	N/C

C. Key/Paddle Jack

Connector Type: 1/4" phone plug

Conn. Pin #	Pod
Tip	DOT
Ring	DASH
Shield	GND

D. Line Out Jack

Connector Type: 1/8" stereo plug

Conn. Pin #.	Pod
Tip	Line Out-L (Main)
Ring	Line Out-R (Sub)
Shield	COM

E. Speakers L/R

Connector Type: 1/8" stereo plug

Conn Pin #	Pod
Tip	spkr-L (Main)
Ring	spkr-R (Sub)
Shield	COM

F. Other Single Pin Connectors (w/shield)

Conn. Type	Pod
RCA-RED	Amp RLY
RCA-WH	PTT
1/8" mono	Line In

G. Unused Pod Connections

Unused	AUX1
Unused	AUX2
Unused	AUX3
Unused	AUX4
Unused	Amp ALC

(2) Selecting Cables and Connectors for Pods: Wiring up multiwire connectors is tedious, so it is best to use commercially made cables whenever possible. Since you've already used your transceivers and amplifiers without a StationPro, you undoubtedly already have most of the necessary cables. But if not, since nearly all transceivers have several RCA phono jacks, you can buy several three foot "stereo cables" and cut them in half. Similarly, you can also buy 1/8" audio cables with molded 1/8" subminiature connectors. Ditto for shielded cables with 1/4" stereo or mono plugs. In other words, it should be possible to purchase most of the needed interface cables for your pods (The one exception: you will probably have to make your own Pod microphone cable). Using purchased cables, the pod assembly will be easy and quick.

(3) Install the connectors on the ends of any custom cables you need, and then cut all the cables to length. Allow 15 inches for cables that plug into rear panel jacks of your transceivers, and 32 inches for cables that plug into front panel jacks. Strip and tin 3/16" from the free end of the cable wires.

(4) Install a 25 pin ferrite-filtered D-Sub female connector (Mouser p/n 806-KF22X-B25S-NJ) on the pod circuit board. Check the solder joints to make sure there are no solder bridges, and be sure to solder the mounting tabs to the pod ground plane, using enough heat for the solder to flow nicely.

(5) Solder the cable ends prepared in step (3) to the appropriate pads on the Pod circuit board, using the list you prepared in Step (1). Take your time to do a neat job, and be careful not to overheat the wires which can cause their insulation to melt. Set aside the Pod circuit board. *Hint: for a particularly neat appearance, slip a length of heat shrink tubing over the cable sleeves, as shown in the above photograph. It is also a good idea to label each cable, as shown in the photograph following step (9).*

(6) In the next few steps, you will prepare the enclosure for the Pod circuit boards. This is a small soft plastic box whose sole purpose is to protect the pod wiring, and it is very easy to work on. It should take you about 15 minutes to prepare one enclosure. The below photograph shows some tools you may find helpful. *Hint: the specified pod enclosure is a Hammond 1591XXBSBK (Mouser p/n 546-1591XXBSBK), but if you need an enclosure right away you can use a Radio Shack "Deluxe Project Case" p/n 270-221, which is nearly the same size.)*

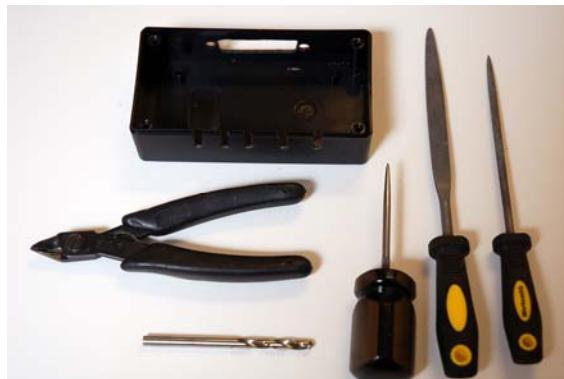

(5) Attach the lid to the plastic enclosure, and then tape the templates shown below (another template copy which you can cut out is at the end of this section, on p. 48) to the front and rear sides of the enclosure. The bottom of the templates should be aligned along the bottom edge of the enclosure. *Hint: using an artist's spray mounting adhesive, available at any arts and crafts store, makes a convenient, removable non-slip way to attach templates to enclosures.*

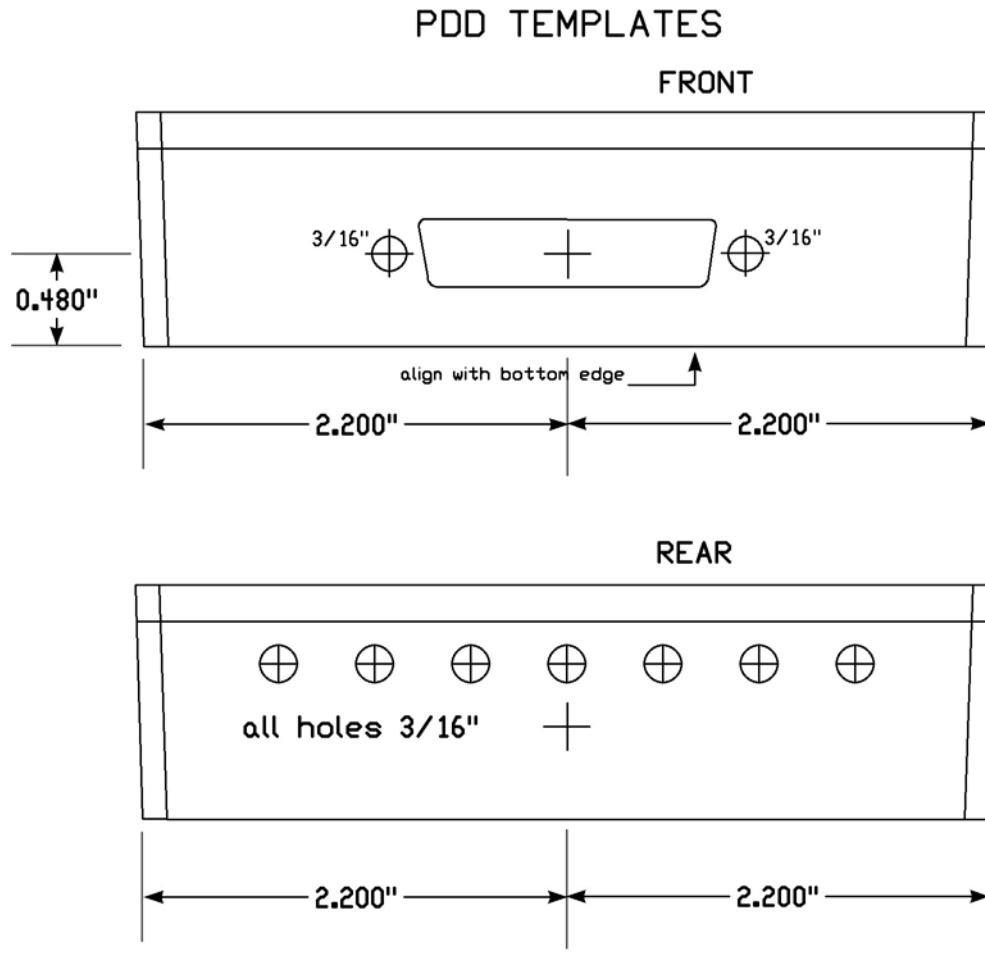

(6) After center-punching the two holes on the front template (any pointed object will work), then drill or punch two 3/16" holes as indicated. The plastic is soft enough that you can probably drill the holes by just holding the bit in your hand.

(7) Using a sharp knife or single-edged razor blade, scribe a scratch along the edge of the cutout for the DB-25 connector. Now remove the template from the front side of the enclosure.

(6) Drill one or more "starter" holes inside the area of the cutout, and then use wire cutters to remove the plastic up to the cutout lines which were scratched into the plastic on the previous step. Use small files to smooth out the jagged edges of the cutout. *Hint: don't worry if your cutout isn't a work of art. The cutout has no structural importance,*

and once the computer cable is plugged into the pod, any imperfections in your workmanship won't be noticeable.

(8) The row of holes along the rear of the enclosure will be made into slots in the next step and are intended for the transceiver cables to feed through. Generally two or more cables will fit through a single slot, so you will probably not need to use all the holes. After you decide how many feedthrough slots you will need, drill or punch 3/16" holes where indicated on the templates. If you prefer, you can omit the holes and just go directly to step (9).

(9) Remove the lid from the enclosure. Using wirecutters, cut vertical slots into the plastic above the holes from the previous step, as illustrated below. If you didn't drill holes in the previous step, then bend the flaps inward; the pressure on the cables from the bent flaps will help secure them.



Completed enclosure with five slots, which hold a total of ten cables (for a Yaesu FT-2000 transceiver)

(9) Mount the pod circuit board on the four posts of the enclosure using No.4 x 3/8" sheet metal screws. Carefully route the cables through the slots in the rear of the enclosure, using cable ties (Ty-Wraps) as strain reliefs. Then install the cover on the enclosure, using the flathead screws provided with the enclosure. This completes the pod assembly.

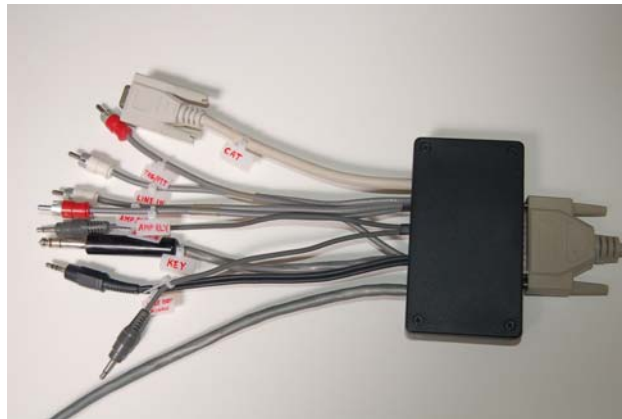

Completed pod for an FT-2000 transceiver.

IX. Final Instructions

(1) You have now completed all the required modules for the StationPro I. All that remains is for you to connect together the Controller Unit, the RF Relay Unit and the transceiver pods, and then to connect your transceivers and linear amplifiers to the StationPro I. Hookup information is contained in **A: StationPro I Operating Instructions** in the beginning of this manual, as well as instructions for operating the StationPro and explanations of its features. You will need to buy two 25 pin “serial” cables (1-male,1-female connector) and one standard 8-pin ethernet cable, all available from any computer or office supply store, or Radio Shack. These cables should be as short as possible, consistent with the layout of equipment on your operating desk. It is preferable to use a shielded ethernet cable, if one is available.

(2) Custom Interface Cable: As noted above, the transceiver pods connect to the StationPro controller unit using a 25-conductor computer cable. For most situations, users will be able to use inexpensive “off the shelf” serial cables. However, for a few situations, specifically when amateurs want to control two transceivers with a computer that has only *one* serial port, while *also* operating SSB or AM, then it *may* be necessary to prepare a custom interface cable. The purpose of the custom cable is to prevent coupling of computer noise from the RS-232 data into the transceivers’ microphone circuits. Please refer to **Supplementary Assembly Manual: Preparing Custom Transceiver Interface Cables** (download from www.w8zr.net/stationpro/download)for a complete discussion of this topic, as well as assembly instructions for making a custom interface cable if you should need one. Most builders will not need to make a custom cable.

PDD TEMPLATES

FRONT

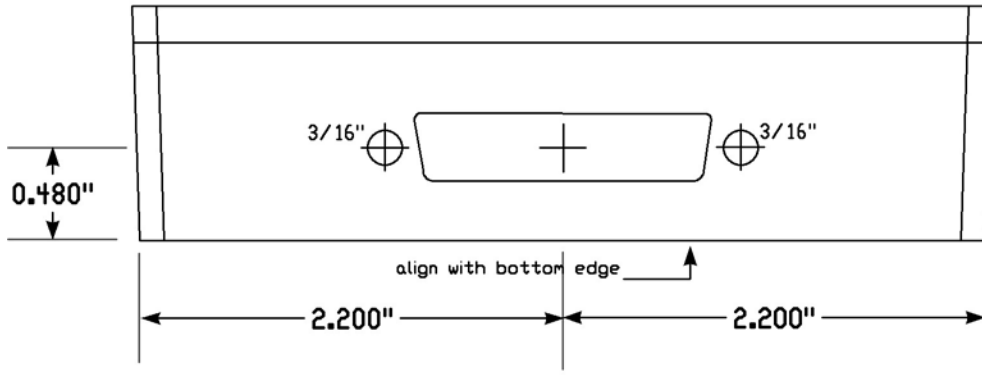

REAR

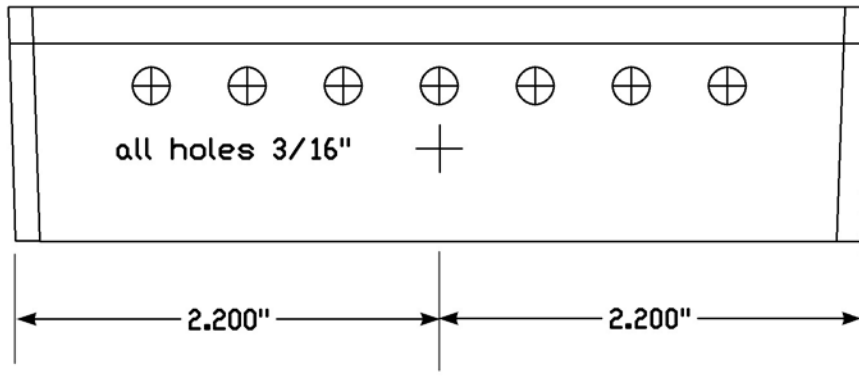

Appendix A: Avoiding Ground Loop Complications

Until about 1975, most amateur microphones such as the venerable Astatic D104 used a two-conductor shielded cable – one conductor for the microphone audio, and one for the push-to-talk line. For such microphones, the grounded shield was connected directly to the transmitter chassis, and both the microphone audio and PTT return currents flowed through the shield.

This arrangement worked satisfactorily only so long as the microphone was plugged directly into a transmitter or transceiver. However, if used with any kind of switching device, or with push-to-talk circuits that used an AC control voltage, these microphones were found to be susceptible to hum and RF feedback.

This problem was solved with the advent of microphones that use two conductors for the audio, typically called “mic+” and “mic-,” and today virtually all amateur microphones use this configuration. By using a dedicated “mic-“ wire for the return audio currents, the low-level microphone voltage is not affected by hum currents on the shield or chassis of connected equipment.

Understanding How Ground Loop Currents Cause Hum

Numerous currents flow along the chassis of any transceiver or transmitter. In vintage vacuum tube transmitters, these might include several amperes of 50/60 Hz filament current, ripple currents from power supply filter capacitors, and 50/60 Hz AC line current from bypass capacitors on the AC line. When a chassis also carries the microphone audio return current, the voltages produced by these AC currents can be a significant fraction of the microphone audio voltage. This AC voltage adds directly to the microphone audio and appears as hum on the transmitted signal.

When a microphone attaches directly to the mic jack in vintage transmitters this hum voltage does not cause a problem, because there are typically only a few inches between the transmitter’s grounded microphone jack and the grid of the first audio amplifier stage. However, when a vintage microphone is routed to the transmitter through a piece of peripheral equipment, such as a VOX adaptor, audio speech processor, or a switching device such as the StationPro, then the AC hum voltage can be quite substantial. In these cases the hum voltage is caused by the AC currents that inevitably flow on the surface of the shielded cable that ties the peripheral equipment to the transceiver. The following diagram shows how these shield currents cause hum when the StationPro is used in connection with a vintage vacuum tube transmitter that uses its chassis for the microphone audio return.

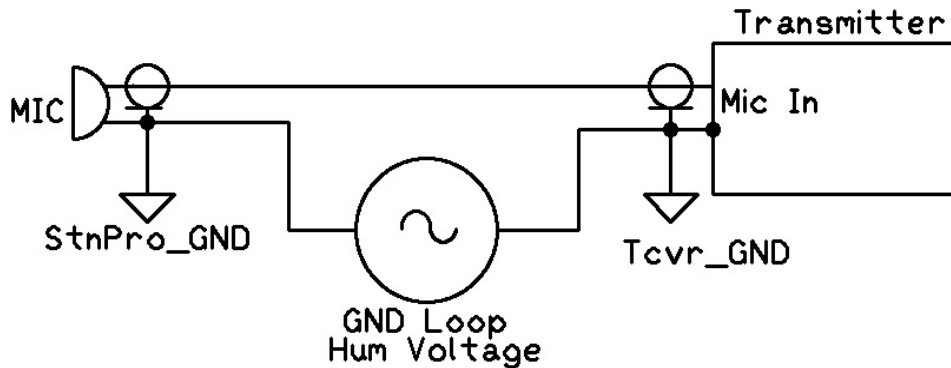

In the diagram, a microphone is connected to the mic jack and chassis of the StationPro, which in turn is routed through a shielded interconnect cable to the mic jack and chassis of the selected transmitter. The transmitter is connected to a 120 VAC or 240 VAC line, and the StationPro is also connected, via the shields of its interconnect cables, to all the other transceivers and linear amplifiers which it controls (each of which is also connected to the AC line, sometimes to multiple AC circuits) The inevitable ground current loops resulting from all these interconnected radios and amplifiers lead to a small AC voltage difference between the StationPro chassis and the chassis of the selected transceiver. In essence, the small AC current flowing on the interconnecting cable shield is a low-impedance hum voltage source. From the diagram we see that this hum voltage is *in series* with the microphone audio voltage, and while it may be only a few millivolts, that is still enough to be heard on a transmitted signal. Note that this hum voltage is not induced “pickup”, e.g., from fluorescent light fixtures, or any indication of inadequate shielding. It rather is caused by AC currents that flow on the outside surface of the interconnecting cable shields.

The diagram below shows why modern microphones with a dedicated “mic-“ connection do not have this problem. In the diagram, there is still an AC voltage caused by ground current loops, but this current flows harmlessly on the outside shield braid. The AC voltage it produces is no longer in series with the microphone audio and therefore causes no hum on the transmitted signal. The bottom line is that StationPro owners who want to use vintage microphones with simple shielded cables (and no separate “mic-“ wire) must take careful steps to minimize audio hum in their stations.

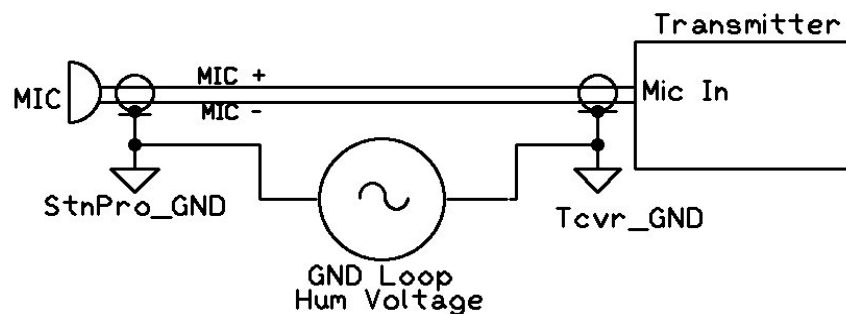

How to Diagnose Ground Loop Problems

The easiest way to diagnose a potential ground loop problem with your StationPro is to jumper the microphone audio terminal to the ground terminal on one of the StationPro's mic connectors. Then key up your transmitter or transceiver and listen to your transmitted signal on a separate receiver. If you hear hum on your signal, even with the mic input shorted to ground, then you have a ground loop. There is no need to worry about this ground loop if you are using a modern microphone with a separate "mic-" wire, but if you wish to use a vintage microphone having a simple shielded cable, then you will definitely have to deal with it.

Basic Steps to Minimize Ground Loop Hum

1. Make sure all of your station transceivers or transmitter/receiver pairs are connected to the same AC circuit and not to separate circuits. (Of course, this will not be possible when using 120 VAC transceivers and 240 VAC amplifiers.)
2. If your transceivers operate off of a +12V power supply, then use that same power supply to power your StationPro. If your power supply has "floating" positive and negative output terminals, do *not* tie the negative terminal to the power supply chassis or to the AC ground terminal on the power supply.
3. Be careful if using a "wall wart" to power your StationPro, because these often have high AC ripple voltages on their +12V outputs. Obviously, to minimize hum, you need a clean +12V power source.
4. Bond the case of the StationPro to the cases of all of your transceivers, linear amplifiers, and power supplies with short braided ground straps. It is best not to "daisy chain" these ground straps from one rig to another, and it is important to use short lengths and as large a conductor as possible. Listen to your transmitted signal (on a dummy load!) and pick the configuration of ground straps that minimizes hum. Because all station layouts are different, trial and error is the only way to find the optimal configuration.

Steps to Take If All Else Fails

If the above steps don't reduce hum to acceptable levels, and you still want to route a vintage microphone through your StationPro, then you will have to take additional measures to isolate the microphone audio from the hum voltage produced by ground loops. Here are suggestions for isolating the microphone audio. Some experimentation will undoubtedly be required to see which gives the best results.

1. Rewire your microphone (and mic connector) so that the microphone element does not use the braided shield for its audio return. Unfortunately, this usually entails replacing the mic cable and connector.

2. If you want to use a “Collins” type two-conductor 3/16 in. mic plug, or a 1/4 in. “stereo” mic plug, then you can electrically insulate the mic jack body from the StationPro front panel by using fiber or nylon insulating washers. (Recall that that these jacks mount in a 3/8 in. hole, whereas the StationPro front panel has 5/8 in. holes for microphone jacks.)



The Collins-type 3/16” mic jack is insulated from the front panel using homemade fiberglass washers on the front and back sides of the panel

As shown in the below diagram, one jumpers the shield terminal on the Collins-type mic jack to the StationPro “Mic-“ header pad on the front panel circuit board, and jumpers the “Mic-“ pad to the GND header pad on the circuit board with a 50 or 100 ohm 1/4 Watt resistor. In this configuration, the ground loop currents which would otherwise flow through the microphone element are short-circuited by the low resistance of the mic- wire in the interconnecting cable, thus reducing the hum voltage to a negligible value. The metal frame of the microphone is still effectively grounded to the StationPro chassis by the 100Ω resistor.

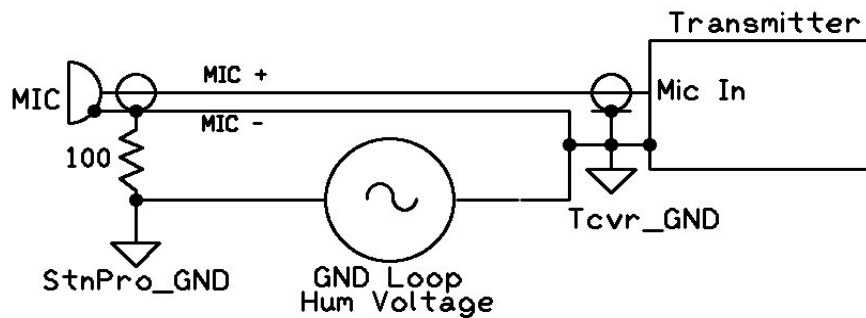

3. Two-conductor mic jacks that mount in a 5/8 in. hole, commonly used in vintage transmitters, pose a special problem because obviously one can’t insulate them from the StationPro’s front panel, as in the above step. For this situation, you can use a small audio interstage transformer to decouple the microphone from the ground loop currents, as shown in the diagram below. With this transformer, the ground loop AC voltage appears only as a common mode voltage on the transformer windings and does not result in any hum. A suitable subminiature transformer is the Model XT-1, sold by Heil Sound at <http://www.heilsound.com/amateur/products/hc104/index.htm>. This transformer may be used to convert a modern low-Z mic to the high-Z output required by most vintage rigs. It may be mounted on the rear of the StationPro’s front panel circuit board with double-stick tape. Suitable 1:1 interstage audio transformers are available from other sources.

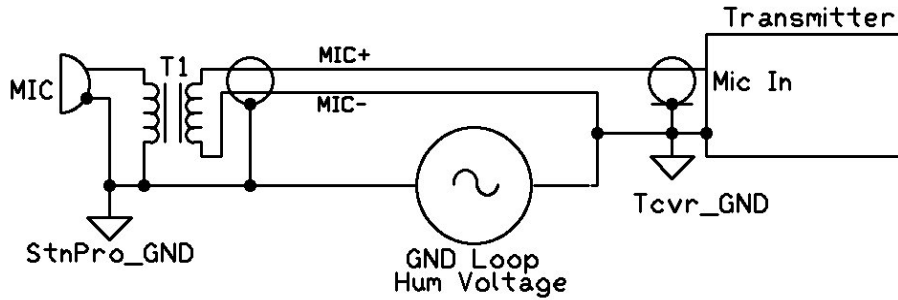

4. And finally, if you don't want to bother with any of the above measures, then you can always bypass the StationPro's microphone jacks and plug your vintage microphones directly into their mating transmitters. For vintage radio collectors, this might be the preferred (and certainly easiest!) solution anyway, since one can then pair a Collins microphone with a Collins KWM-2 transceiver, a Drake microphone with a Drake TR-4 transceiver, and so forth.

Appendix B: StationPro I Parts & Supplier List

(rev.5/25/2010)

Notes: (1) Primary supplier is Mouser Electronics (www.mouser.com).
 (2) Secondary and alternate suppliers are Digikey Electronics, Allied Electronics, All Electronics, Jameco Electronics
 (3) Prices listed are approximations only of current prices
 (4) Patch cables (1 – CAT 5 w/RJ45 connectors, 3 – 25C w/DB25 connectors) are listed without suppliers, since lengths depend on user's station. Should be obtained locally.

Main Circuit Board -ver C0

C101	0.1 μ F	Capacitor 50V Xicon Z5U epoxy dipped ceramic, qty 1 Mouser p/n 21RZ310-RC Price: \$.08/ea, \$.069/100, \$.053/500, \$.046/1000
D101 - D107	1N4005	Fairchild 1A diode, qty 7 Mouser 512-1N4005 Price: \$0.05/ea, \$0.04/10, \$0.03/100, \$0.02/250
F101	Fuse Clips	Keystone 0.25" 3529 PCB fuse clips, qty 2 Mouser p/n 534-3529 Price: \$0.14/ea, \$0.10/10, \$0.08/100, \$0.07/500
F101	Fuse	Fuse 1Amp 3AG, qty 1 Mouser p/n 504-AGC-1 Price \$0.30/ea, \$0.24/25, \$0.22/50
J101-J104	Connector	Molex 09-52-3123 12pin, .156" top-entry header, qty 4 Mouser p/n 538-09-52-3123 Price: \$1.75/ea, \$1.57/10, \$0.41/100, \$1.25/500
J105, J106	Connector	Molex 09-52-3043 4-pin .156" top-entry header, qty 2 Mouser p/n 538-09-52-3043 Price: \$0.60/ea, \$0.52/10, \$0.33/100, \$0.28/500
J107	Connector	2.5mm DC pwr jack, PCB side entry, qty 1 Mouser p/n 806-KLDX-0202-BC Price: \$0.46/ea, \$0.44/25, \$0.32/100, \$0.25/500
J108, J109	Connector	D-Sub 25 pin male, R/A PCB Mount, qty 2 Mouser p/n 636-182-025-113R531 (Norcomp) Price \$1.69/ea, \$1.62/10, \$1.18/100, \$1.10/250, \$1.05/500 (alternate) Mouser p/n 806-KF22X-B25P-NJ

J110	Connector	D-Sub Kycon 9 pin female, R/A PCB Mount, qty 1 Mouser p/n 806-KF22X-E9S-NJ (ferrite filtered) Price: \$3.40/ea, \$2.90/25, \$2.48/50, \$2.00/100
J111	Connector	DIN 5 pin female PCB side-entry, qty 1 Mouser p/n 161-0505 Price: \$1.10/ea, \$0.92/10, \$0.76/100, \$0.69/500
J112	Connector	RJ45 8pin PCB side-entry, shielded, qty 1 Mouser p/n 571-5555153-1 Price \$1.09/ea, \$0.87/10, \$0.71/100, \$0.62/500
K101 –K113	Relay	P&B/Tyco V23105, DPDT 12VDC/960 ohm coil, qty 13 Mouser p/n 655-V23105A5003A201 Price: \$1.75/ea, \$1.58/25, \$1.40/50, \$1.26/100
K114	SS Relay	Clare Optomos PLA140 solid state relay, qty 1 Mouser p/n 849-PLA140 Price \$4.34/ea, \$3.82/25, \$3.48/50, \$3.18/100, \$2.87/250
P101, P103	Connector	Molex 10-89-7262, 2x13 pin, 0.100 female header, qty 2 Mouser p/n 538-10-89-7262 Price \$1.89/ea, \$1.65/10, \$1.24/100, \$0.99/500
P102	Connector	Molex 26-60-4040 K.K. 4-pin .156 header, qty 1 Mouser p/n 538-26-60-4040 Price \$0.44/ea, 0.38/10, \$0.25/100, \$0.20/500
Q101	2N3906	Fairchild 2N3906 PNP gen purpose transistor, TO92, qty 1 Mouser 512-2N3906TA Price: \$0.04/ea, \$0.034/10, \$0.028/100, \$0.020/250
R102, R103	2.2 K Ω	Resistor, Xicon 5% carbon film 1/4W, qty 10 (min order) Mouser p/n 291-Value-RC (e.g., 291-4.7K-RC) Price: \$0.09/10, \$0.044/200, \$0.017/1000
R104, R105, R106	1 K Ω	
---	hardware	threaded spacer, rnd aluminum, (6-32)x1/2", qty 6 Mouser p/n 534-3487 Price \$0.33, \$0.24/100,

***** Parts for optional amp relay keying circuit (delete K114, R106 if used) *****

(R101)	4.7 K Ω	Resistor, Xicon 5% carbon film 1/4W, qty 10 (min order) Mouser p/n 291-Value-RC (e.g., 291-4.7K-RC) Price: \$0.09/10, \$0.044/200, \$0.017/1000
--------	----------------	---

(D108) 1N4005 Fairchild 1A diode, qty 1
 Mouser 512-1N4005
 Price: \$0.05/ea, \$0.04/10, \$0.03/100, \$0.02/250

(Q102) IRF610PBF MOSFET, N-chan, 200V/ 3.3A, qty 1
 Mouser p/n 844-IRF610PBF
 Price \$0.48, \$0.39/10, \$0.35/100, \$0.31/500

B. Front Panel Circuit Board (StationPro I Version A3)

C301-C306 1000pF Capacitor, 50V Xicon, X7R, qty 6
 Mouser p/n 21RX510-RC
 Price \$0.10/ea, \$0.084/100, \$0.065/500

DS301- DS304 LED-GR Lumex LED, Green, 5mm, qty 4
 Mouser p/n 696-SSL-LX5093LGD
 Price: \$0.12/ea, \$0.10/100, \$0.08/500, \$0.07/1000

DS306-DS308 LED-YE Lumex LED, Yellow, 5mm, qty 3
 Mouser p/n 696-SSL-LX5093LYD
 Price: \$0.15/ea, \$0.12/100, \$0.10/500, \$0.08/1000

DS305 LED-RE Lumex LED, Red, 5mm, qty 1
 Mouser p/n 696-SSL-LX5093LID
 Price: \$0.15/ea, \$0.12/100, \$0.10/500, \$0.08/1000

-- LED bezels LED Mounting Clips, qty 8
 Mouser p/n 593-CLP125
 Price: \$0.09/ea, \$0.08/10, \$0.07/100, \$0.06/500

H301 Header (unused)

J301 Connector 1/4 in. Stereo NO Phone Jack, qty 1
 Mouser p/n 568-NYS230
 Price \$1.08/ea, \$0.98/10, \$0.88/100, \$0/82/500

J302 Connector 1/4 in. Stereo NO/NC Phone Jack, qty 1
 Mouser p/n 502-L-114BX
 Price \$4.66, \$3.80/10, \$3.10/25, \$2.65/100

J303 Connector 3.5 mm Stereo NO/NC Kycon Phone Jack, qty 1
 Mouser p/n 806-STX-3150-5C
 Price \$1.03/ea, \$0.69/25, \$0.65/100, \$0.56/500

K301	Relay	P&B/Tyco V23105, DPDT 12VDC/960 ohm coil, qty 1 Mouser p/n 655-V23105A5003A201 Price: \$1.75/ea, \$1.58/25, \$1.40/50, \$1.26/100
P301	Header	Molex 10-89-7262, 2x13 pin, 0.100 male header, qty 1 Mouser p/n 538-10-89-7262 Price \$1.89/ea, \$1.65/10, \$1.24/100, \$0.99/500
P302	Header	Molex 26-60-4040 K.K. 4-pin .156 header, qty 1 Mouser p/n 538-26-60-4040 (tin) Price \$0.44/ea, 0.38/10, \$0.25/100, \$0.20/500
R301	1 K Ω	Resistor, Xicon 5% carbon film 1 Watt, qty 1 Mouser p/n 294-1K-RC
R302-R304	2.2 K Ω	Resistor, Xicon 5% carbon film 1/4W, qty 10 min Mouser p/n 291-VALUE-RC (e.g., 291-2.2K-RC) Price: \$0.09/10, \$0.044/200, \$0.017/1100
S301	Switch	Mountain Switch DPDT paddle, qty 1 Mouser p/n 103-4024-EV Price: \$2.90/ea, \$2.62/50, \$2.47/100, \$2.32/500
S302-S305	Switch	Mountain Switch, min. toggle, flat lever, SPDT, qty 4 Mouser p/n 1055-TA2130-EVX Price: \$2.67/ea, \$2.23/50, \$2.02/100, \$1.84/500

C. Rear Panel Circuit Board –ver A3

C401-419	1000 pF	Capacitor, 200V, Mallory, qty 19 Mouser p/n 539-CK05102K Price \$0.27/ea, \$0.21/100, \$0.19/500, \$0.18/1000
C420	0.1 μ F	Capacitor 50V Xicon Z5U epoxy dipped ceramic, qty 1 Mouser p/n 21RZ310-RC Price: \$.08/ea, \$.069/100, \$.053/500, \$.046/1000
J401	Connector	Neutrik 1/4 in 2-circuit PCB phone jack, qty 1 Mouser p/n 550-20301 Price: \$0.66/ea, \$0.60/10; \$0.51/100
J402	Connector	Kobiconn 3.5mm 1-circuit PCB phone jack, qty 1 Mouser p/n 161-3520-EX Price: \$1.50/ea, \$1.00/10, \$0.91/100 \$0.83/500

J403	Connector	Kobiconn 3.5mm 2-circuit PCB phone jack, qty 1 Mouser p/n 161-3507-E Price: \$0.79/ea, \$0.53/10, \$0.48/100
J404, J405	Connector	Kobiconn triple RCA phono jack (R/Wh/Ye), qty 2 Mouser p/n 161-4319-E Price: \$1.37/ea, \$1.14/10, \$1.04/100, \$0.95/500
J406-J409	Connector	Kobiconn dual RCA phono jack (R/Wh), qty 4 Mouser p/n 161-4219-E Price: \$0.57, \$0.44/10, \$0.40/100, \$0.39/500
J410	Connector	2.5mm DC pwr jack, PCB side entry, qty 1 Mouser p/n 806-KLDX-0202-BC Price: \$0.46/ea, \$0.44/25, \$0.32/100, \$0.25/500
P403	Header	Molex 10-89-7262, 2x13 pin, 0.100 male header, qty 1 Mouser p/n 538-10-89-7262 Price \$1.89/ea, \$1.65/10, \$1.24/100, \$0.99/500

D. Chassis/Misc

-----	Enclosure	Ten-Tec 9"x 4"x 7" custom punched, silkscreened
P101 to P301 P103 to P403	ribbon cable	3M .100" 26C molded cable assembly, 6", qty 2 Mouser p/n 517-1M-1010-026-6 Price: \$4.72/ea, \$4.26/5, \$3.86/10, \$3.13/200, \$3.01/1000
Jumper header	Header	Molex .156 12 pin header, qty 4 Mouser p/n 536-26-60-2120 Price: \$0.77, \$0.69/10, \$0.66/100, \$0.63/500
Jumper header	Header	Molex .156 4 pin header, qty 2 Mouser p/n 536-26-60-2040 Price: \$0.27, \$0.28/10, \$0.18/100, \$0.15/500
Connector Housing	Connector	Molex .156 4-pin nylon housing, w/locking ramp, qty 2 Mouser p/n 538-09-50-3041 Price: \$0.25, \$0.21/10, \$0.15/100, \$0.13/500
		Molex .156" crimp terminals, qty 8 Mouser p/n 538-08-50-0134 Price: \$0.08, \$0.06/100, \$0.05/500, \$0.04/1000

E. RF Relay Switching Unit - ver A2

----	Enclosure	Ten-Tec custom silkscreened, prepunched (Alternate)Hammond 7.4"x 4.7"x 1.3 "die cast w/flange, qty 1, not silkscreened or punched. Mouser p/n 546-1590DDF Price: \$26.58/ea
Coax In/Out	Connector	UHF SO-239 AIM/Cambridge chassis, qty 10 Mouser p/n 601-25-7350 Price \$1.33/ea, \$1.21/10, \$1.06/25, \$1.01/100, \$0.95/500
J501	Connector	RJ-45 8 pin, top entry, shielded, PCB mount, qty 1 Mouser p/n 571-5557969-2 Price \$3.26/ea, \$2.95/25, \$2.64/50, \$2.40/100
K501-K510		Tyco/Schrack RTB14012F SPDT 12A, qty 10 Mouser p/n 655-RTB14012F Price \$1.73/ea, \$1.51/25, \$1.36/50, \$1.20/100 (alternate – preferred for VHF) Panasonic JW1FSN-DC12V SPDT 10A, qty 10 Mouser p/n 769-JW1FSN-DC12V Price \$2.76/ea, \$2.53/25, \$2.30/50, \$2.07/100
C501-C507	0.01 μ F	Capacitor 50V Xicon Z5U epoxy dipped ceramic, qty 7 Mouser p/n 21RZ410-RC Price: \$.08/ea, \$.069/100, \$.053/500, \$.046/1000
C508	0.1 μ F	Capacitor 50V Xicon Z5U epoxy dipped ceramic, qty 1 Mouser p/n 21RZ310-RC Price: \$.08/ea, \$.069/100, \$.053/500, \$.046/1000
D501-D507	1N914A	Fairchild Si signal diode, DO-35, qty 7 Mouser 512-1N914 Price: \$0.03/ea, \$0.02/10, \$0.015/100, \$0.01/250
---	hardware	threaded spacer, rnd aluminum (4-40) x 1/4" qty 4 Mouser 534-2025 Price: \$0.34ea, \$0.19/100

F. Transceiver Pods – ver B0 (quantities are for 2 pods)

----	Enclosure	Hammond 4.4"x 2.5"x 1.1 " plastic enclosure, qty 2
------	-----------	--

Mouser p/n 546-1591XXBSBK

Price: \$4.06/ea, \$3.66/10, \$3.03/50, \$2.62/100

---- cable ties cable ties, Ty-Wrap or equiv., 4 inch, qty 10

Pod Conn. Connector

D-Sub 25 pin female, R/A, PCB mount, qty 2

Mouser p/n 806-KF22X-B25S-NJ (Kycon, ferrite filtered)

Price \$4.38/ea, \$4.09/25, \$2.99/50, \$2.63/100

G. Misc Hardware and Other Items

- Qty 18 No. 4 x 3/8" sheet metal screws (six to secure rear panel circuit board to rear panel, eight to attach pod circuit boards to their plastic enclosures, three to secure blank-off plate to rear panel, plus four spares.)
- Qty 8 No. 6 x 3/8" sheet metal screws, black oxide coated (to attach cover to RF enclosure)
- Qty 8 4-40 x 3/16" machine screws (to attach rly PCB to RF relay enclosure)
- Qty 20 4-40 x 5/16" machine screws (to secure SO-239s to RF relay enclosure)
- Qty 8 6-32 x 1/4" machine screws (to secure main circuit board to bottom plate of enclosure)
- Qty 28 No. 4 internal tooth lockwashers
- Qty 8 No. 6 internal tooth lockwashers
- Qty 20 4-40 nuts
- Qty 8 2-56 x 3/16" machine screws (used in SPII upgrade kit)

Note: additional hardware is supplied with the custom enclosure for the StationPro I control unit. The following items should be obtained locally.

- Qty 2 patch cord 3'-6' 25C serial cable w. male/female DB25 connectors
- Qty 1 patch cord 3'-6' CAT5 patch cord w/RJ45 connectors (shielded preferable)
- Qty 15 cable ties 4" nom., Ty-Wrap or equivalent